



Service Manual

For Service Manuals Contact
MAURITRON TECHNICAL SERVICES
8 Cherry Tree Rd, Chinnor
Oxon OX9 4QY
Tel:- 01844-351694 Fax:- 01844-352554
Email:- enquiries@mauritron.co.uk

Nakamichi 480

2 Head Cassette Deck

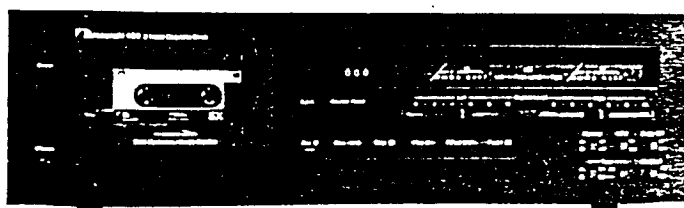

- 1. General 3
- 2. Principle of Operation 4
 - 2. 1. Mechanisms 4
 - 2.1.1. Headblock 4
 - 2.1.2. Erase Head 5
 - 2.1.3. Double Capstan Tape Drive 5
 - 2.1.4. Mechanism Control Cam Operation 6
 - 2. 2. Amp. Circuits 7
 - 2.2.1. Playback Eq. Amp. Circuit 7
 - 2.2.2. Record Eq. Amp. Circuit 9
 - 2.2.3. Bias Osc. Circuit 9
 - 2. 3. Mechanism Control Circuits 10
 - 2.3.1. Outline 10
 - 2.3.2. +12 V Power Source 11
 - 2.3.3. Power-mute Signal 11
 - 2.3.4. Auto Shut-off Circuit 11
 - 2.3.5. Record Control Circuit 14
 - 2.3.6. Mute Signal 14
 - 2.3.7. Control Motor Drive Circuit 15
 - 2.3.8. Reel Motor Governor 17
- 3. Removal Procedures 17
 - 3. 1. Cassette Case Cover Ass'y 17
 - 3. 2. Top Cover Ass'y 17
 - 3. 3. Bottom Cover Ass'y 17
 - 3. 4. Front Panel Ass'y 17
 - 3. 5. Headphone Jack Ass'y 18
 - 3. 6. Mechanism Ass'y 18
 - 3. 7. Meter Ass'y 18
 - 3. 8. Lamp P.C.B. R Ass'y and Lamp P.C.B. L Ass'y 18
 - 3. 9. Main P.C.B. Ass'y 19
 - 3. 10. Control Switch Holder Ass'y 19
 - 3. 11. Switch P.C.B. Ass'y 19
 - 3. 12. Volume P.C.B. Ass'y and Control Switch P.C.B. Ass'y 19
 - 3. 13. Rear Panel Ass'y, Power Transformer and Power Switch 19
 - 3. 14. Cassette Case Ass'y and Cover Plate Ass'y 20
 - 3. 15. Tape Counter Ass'y 20
 - 3. 16. Capstan Motor Ass'y and Flywheel Ass'y 21
 - 3. 17. Sub Mechanism Chassis Ass'y 21
 - 3. 18. Control Motor Ass'y and Reel Motor Ass'y 21
 - 3. 19. Cam Control Volume 21
 - 3. 20. Reel Hub Ass'y and Idler Ass'y 21
 - 3. 21. Cam Drive Gear and Control Cam 21
 - 3. 22. Head Mount Base Ass'y 21
 - 3. 23. Pressure Roller Ass'y and Erase Head 22
 - 3. 24. Record/Playback Head Ass'y 22
- 4. Measurement Instruments 23
- 5. Mechanical Adjustments 24
 - 5. 1. Mechanism Control Cam Adjustment 24
 - 5. 2. Tape Speed Adjustment 25
 - 5. 3. Record/Playback Head Tilt Adjustment 25
 - 5. 4. Head Base Stroke Adjustment 26
 - 5. 5. Tape Guides Adjustment and Erase Head Stroke Adjustment 27
 - 5. 6. Erase Head Height and Tilt Adjustment 28
 - 5. 7. Record/Playback Head Height Adjustment and Azimuth Alignment 28
 - 5. 8. Tape Travelling Adjustment 29
 - 5. 9. Record Switch Linkage Adjustment 29

- 5. 10. Flywheel Holder Adjustment 30
- 5. 11. Eject Wire Adjustment 30
- 5. 12. Lubrication 30
- 6. Parts Location for Electrical Adjustment 31
- 7. Electrical Adjustments and Measurements 32
 - 7. 1. Adjustment and Measurement Instructions 32
 - 7. 2. Playback Frequency Response Adjustment 35
 - 7. 3. Check on Dolby NR Circuit 35
- 8. Mounting Diagrams and Parts List 36
 - 8. 1. Volume P.C.B. Ass'y 36
 - 8. 2. Control Switch P.C.B. Ass'y 36
 - 8. 3. Switch P.C.B. Ass'y 36
 - 8. 4. Control P.C.B. Ass'y 36
 - 8. 5. Auto Shut-off P.C.B. Ass'y 36
 - 8. 6. Lamp P.C.B. L Ass'y 36
 - 8. 7. Lamp P.C.B. R Ass'y 36
 - 8. 8. Main P.C.B. Ass'y 37
- 9. Mechanism Ass'y and Parts List 41
 - 9. 1. Synthesis 41
 - 9. 2. Front Panel Ass'y (A01) 41
 - 9. 3. Synthesis Mechanism Ass'y (A02) 41
 - 9. 4. Meter Escutcheon Ass'y (B01) 42
 - 9. 5. Control Switch Holder Ass'y (B02) 43
 - 9. 6. Headphone Jack Ass'y (B03) 43
 - 9. 7. Mechanism Ass'y 480 (B04) 44
 - 9. 8. Chassis Ass'y (B05) 45
 - 9. 9. Flywheel Holder Ass'y (C01) 45
 - 9. 10. Sub Mechanism Chassis Ass'y (C02) 46
 - 9. 11. Main Mechanism Chassis Ass'y (C03) 48
 - 9. 12. Rear Panel Ass'y (D01) 49
 - 9. 13. Reel Motor Ass'y (E01) 50
 - 9. 14. Control Motor Ass'y (E02) 50
 - 9. 15. Head Mount Base Ass'y (F01) 50
 - 9. 16. Supply Pressure Roller Ass'y (F02) 50
 - 9. 17. Take-up Pressure Roller Ass'y (F03) 50
 - 9. 18. Head Base Ass'y C (F04) 51
 - 9. 19. Cassette Case Holder L Ass'y (F05) 51
 - 9. 20. Cassette Case Holder R Ass'y (F06) 51
 - 9. 21. Auto Shut-off Ass'y (F07) 51
 - 9. 22. Pneumatic Damper Ass'y (F08) 51
 - 9. 23. RP-9E Record/Playback Head Ass'y (G01) 51
- 10. Overall Timing Chart 53
- 11. Eq. Amp. Frequency Response 54
 - 11. 1. Playback Frequency Response 54
 - 11. 2. Record Current Frequency Response 54
- 12. Wiring Diagram 55
- 13. Block Diagrams 57
 - 13. 1. Amplifier 57
 - 13. 2. Mechanism Control 58
- 14. Schematic Diagrams 59
- 15. Specifications 62

For Service Manuals Contact
 MAURITRON TECHNICAL SERVICES
 8 Cherry Tree Rd, Chinnor
 Oxon OX9 4QY
 Tel: 01844 351694 Fax: 01844 352554
 Email: enquiries@mauritron.co.uk

1. GENERAL

1.1. Control Functions

Nakamichi 480 control functions are shown below:

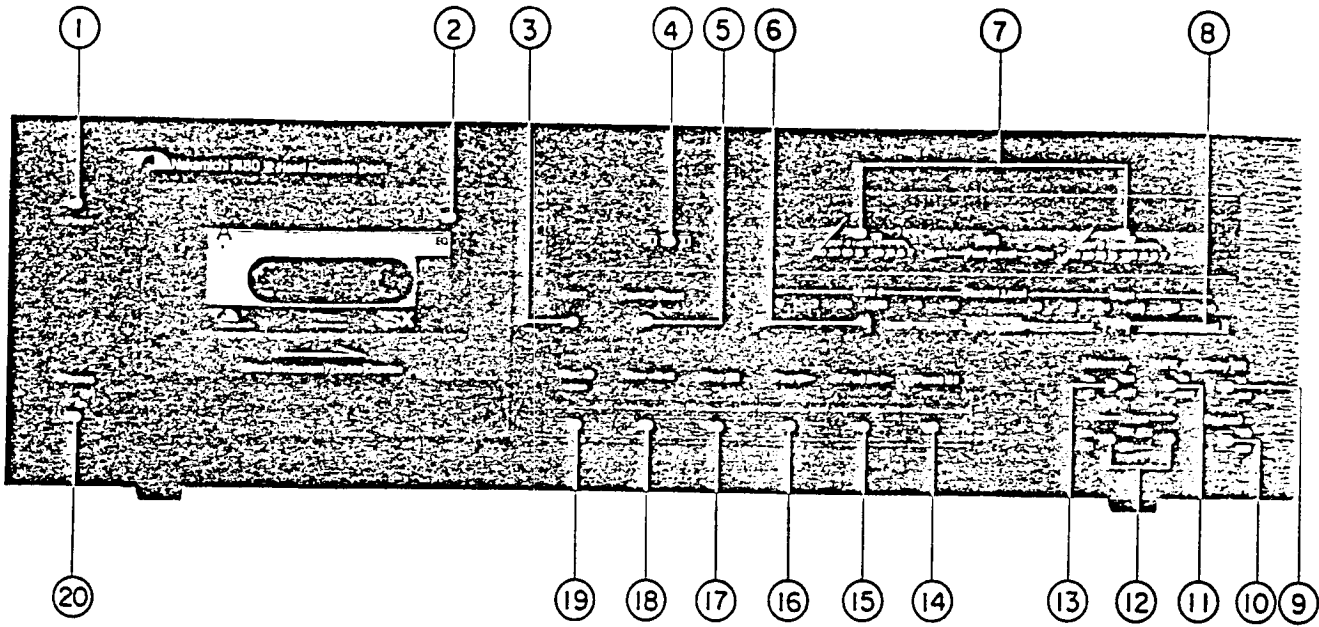

Fig. 1.1 Front View

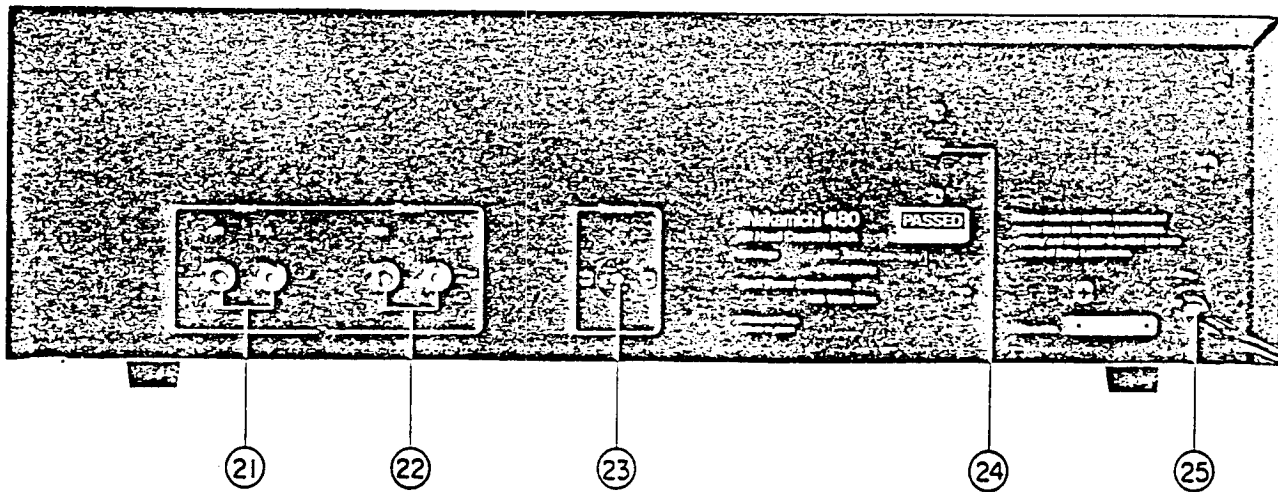

Fig. 1.2 Rear View

- | | |
|--|-----------------------------|
| 1. Power Switch | 14. Pause Button |
| 2. Cassette Lid | 15. Fast-Forward Button |
| 3. Eject Button | 16. Play Button |
| 4. Tape Counter | 17. Stop Button |
| 5. Counter Reset Button | 18. Rewind Button |
| 6. Input Level Control - Left Channel | 19. Record Button |
| 7. Peak Level Meters | 20. Headphone Jack |
| 8. Input Level Control - Right Channel | 21. Input Jacks |
| 9. Dolby NR Switch | 22. Output Jacks |
| 10. Eq. Switch | 23. Remote Control Socket |
| 11. MPX Filter Switch | 24. Voltage Selector Switch |
| 12. Tape Selector Switches | 25. Power Cord |
| 13. Tape Memory Switch | |

1.2. Voltage Selector

Voltage selector is installed on the rear panel for other versions of the Nakamichi 480. This voltage selector can select either 120 V or 220 - 240 V at customer's disposal.

2. PRINCIPLE OF OPERATION

2.1. Mechanisms

2.1.1. Headblock

Refer to Fig. 2.1.1 Headblock.

Nakamichi 480 Headblock provides more stabilized tape travel.

Accuracy of tape travel is one of the most essential factors for a device to optimize its performance. Inaccurate tape travel will therefore induce deterioration exemplified by the following:

- vibration will be given to tape travel, as a result of which flutter and modulation noise will become increased
- insufficient tape-to-head contact will result in level drops
- tape skew will become greater and frequency response will become decreased

Needless to say, constant tape travel must consist of smooth drive mechanism, as well as of the fact that tape, heads and tape guide are placed in the most appropriate positions.

N-480 Record/Playback Head is made small in size. Erase Head is located at the place where the Record Head is located in the N-700II/1000II.

Record/Playback Head is assembled on the Head Mount Base. Take-up Tape Guide and Supply Tape Guide are fixed to the Take-up and Supply Pressure Rollers respectively. Erase Head is placed on the Head Base. All these can be separately adjusted. Shape of the Heads and its location have been carefully studied to bring about smoother contact of tape with the Heads. Pad Lifter is affixed to the Record/Playback Head so as not to let Tape Pad touch the Head to give more stabilized tape travel, making it free from the influence of the Tape Pad within the Cassette Tape. Thus the trouble of changes in azimuth can now be avoided at changing of cassette tape, if only the Record Head azimuth is properly adjusted in advance.

(1) Adjustment of Tape Guide Height

Tape Guides for the N-480 are affixed to the Supply Pressure Roller Ass'y and Take-up Pressure Roller Ass'y. With springs in the studs of Main Mechanism Chassis Ass'y, the Supply Pressure Roller Ass'y and Take-up Pressure Roller Ass'y are tightly affixed with Tape Guide Adjustment Nuts. The Adjustment Nuts are placed on the springs, and therefore either by tightening or loosening, height adjustment of the Tape Guides will become possible.

(2) Record/Playback Head Height Adjustment and Azimuth Alignment

Azimuth and height of Record/Playback Head are independent from each other and adjustment may be done separately without affecting others. In order to adjust the tilt of Record/Playback Head backwards or frontwards, take off the Height Gear Stopper and take out the Height Gear and then turn the two Height Adjustment Screws. After completion of adjustment, place the Height Gear back and fix it with the Height Gear Stopper. After the tilt is adjusted in such a way as above, adjust the height by turning the Height Gear. Azimuth is aligned by turning the Azimuth Alignment Screw. This system has been carefully designed so as to minimize influence each other between azimuth alignment and height adjustment.

(3) Erase Head Height and Tilt Adjustment

Erase Head is affixed onto the Erase Head Plate which is assembled with the Head Base. It is installed with three screws. By turning these screws, its height, tilt of backward or forward, and tilt of leftward or rightward can be adjusted separately, thus the best location of Erase Head can be obtained.

For Service Manuals Contact
MAURITRON TECHNICAL SERVICES
 8 Cherry Tree Rd, Chinnor
 Oxon OX9 4QY
 Tel:- 01844-351694 Fax:- 01844-352554
 Email:- enquires@mauritron.co.uk

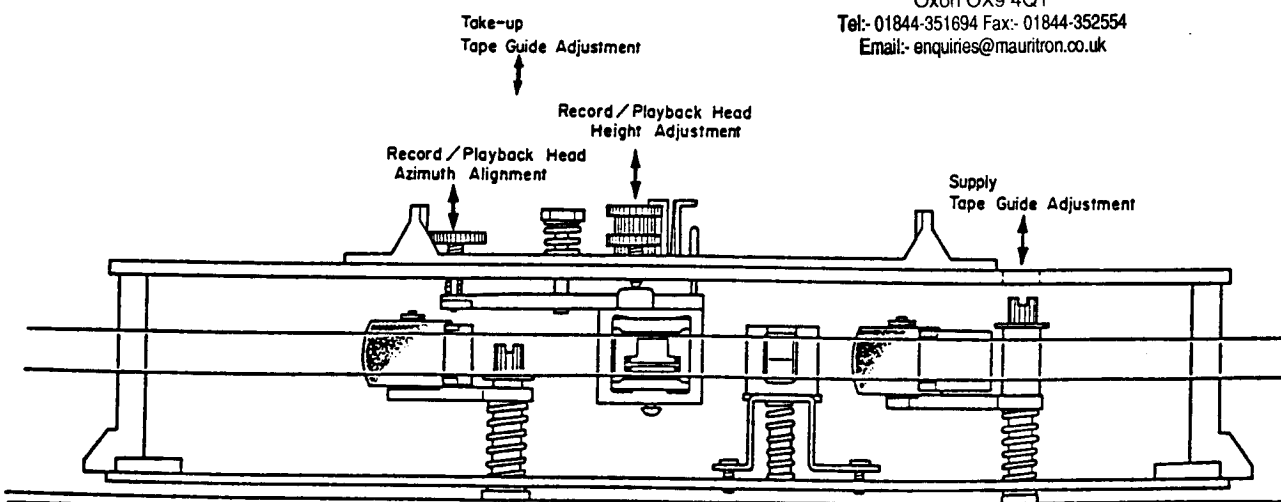

Fig. 2.1.1 Headblock

2.1.2. Erase Head

Fig. 2.1.2 shows the sectional view of the Erase Head. Fig. 2.1.3 shows the characteristics of erasing current and erasure.

It has the same characteristics with the previous type Direct-Flux Erase Head but been purposely developed to minimize the size further.

Conventional Erase Head had its inside core narrower than its outside core, while this Erase Head is equipped with an inside core wider than the outside core. This has resulted more power sufficient enough for erasing with small power consumption, approx. 0.5 W, though the head width is as small as 3 mm. The smaller the power consumption is, the smaller will be the heat generation, and this is of course another merit.

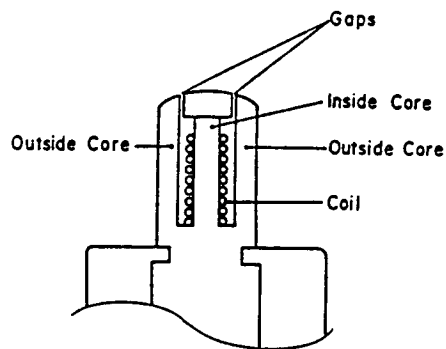

Fig. 2.1.2 Sectional View of Erase Head

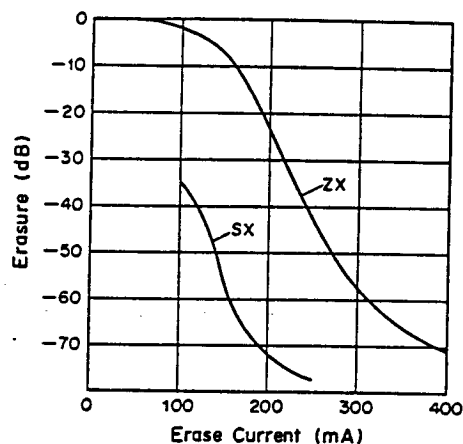

Fig. 2.1.3 Characteristics of Erasing Current and Erasure

2.1.3. Double Capstan Tape Drive

As shown in Fig. 2.1.4, the double capstan system consists of two capstan shafts (a) and (b) connected to the two flywheels which are driven by a capstan belt.

Against these capstans two pressure rollers (a) and (b) are engaged to run the tape with an adequate holdback tension created by the double capstan and pressure rollers. Since the diameter of capstan shaft (a) is smaller than that of capstan shaft (b), when two flywheels begin to turn as shown in the figure, capstan (a) runs slightly faster than capstan (b), which subsequently generates holdback tension.

As you note, if the diameters of the 2 capstans should be the same, the generation cycles of wow and flutter will become approximately the same, as a result of which defective portion will be doubly superposed and preferable portion vice versa. The N-480 employs 2 capstans, each having different diameter and rotations, thereby avoiding the aforesaid occurrence and stabilizing wow and flutter characteristics.

As the double capstan system always creates a constant and stable holdback tension between the two capstans, the condition of the tape between two capstans will not be affected by any external conditions such as irregular take-up and supply torques, irregular loading of cassette tape, undesirable mechanism vibration and etc., thus assuring the superior wow and flutter characteristics. The double capstan system provides a constant holdback tension on the tape and maintains the stable pressure onto the tape against the heads.

The only critical factor in the double capstan system is to be considered; the two capstans have to be positioned perfectly in parallel and to be precisely vertical against the head base, the pressure rollers have to be evenly pressed against the capstan shafts and the head surface must be positioned perfectly vertical to the tape surface. Otherwise, the running tape might become out of the tape guide resulting in irregular movement.

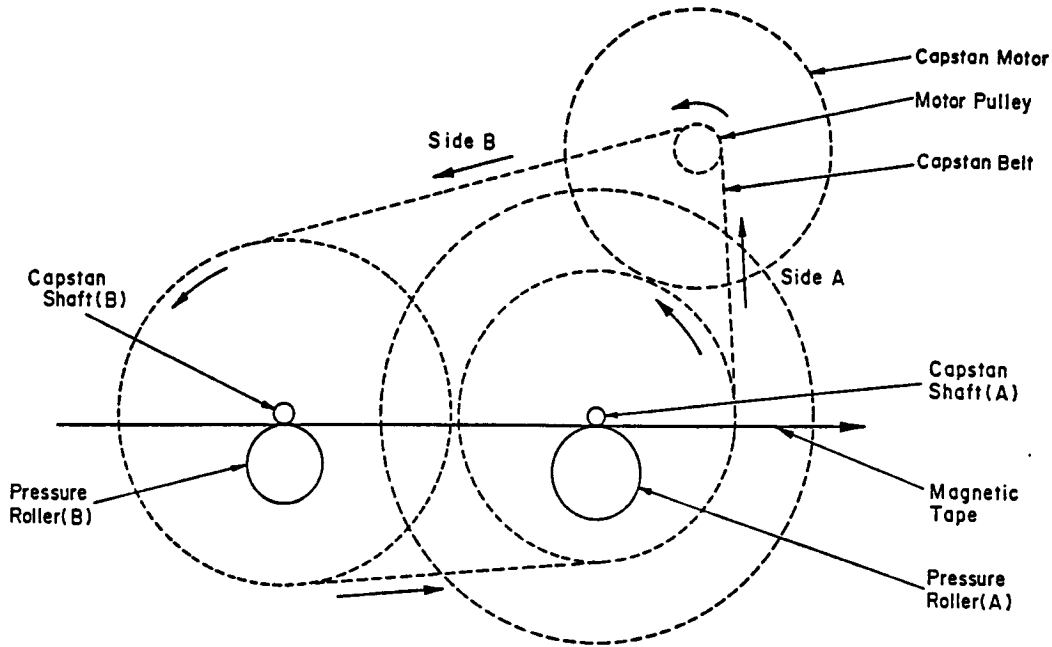

Fig. 2.1.4 Double Capstan Tape Drive

2.1.4. Mechanism Control Cam Operation

Refer to Fig. 2.1.5 Mechanism Control Cam timing chart. Function of N-480 Mechanism is done by Cam Control. Cam is driven by the Control Motor. The Motor operates so as to result zero in the difference of voltages between each voltage corresponding to mechanism function and each reference voltage which corresponds to each commands of the Control Switch. When the difference comes to zero, then it stops. In this way, each function is kept properly operated. For further details, please see the explanation on Logic Control. Here we explain principle of its mechanical functions.

Cam Control System works as follows: Cam Drive Gear is driven by Control Motor by means of Drive Belt. Cam Drive Gear is related to the cam with which each function may be mechanically set on.

(1) Play Mode

Press the Play Switch to make it Play mode. Then the Cam begins to move from Stop position to Play position and the Play mode will be set.

The Head Base which is linked to the Cam and which is normally pushed against the Stop position gets released and the Head Base will slowly come out for playing. To explain this function, first the Head Base is latched and the Reel Motor begins to turn. Then the Pressure Roller will be pushed and the Brake will be released. Now the tape begins to run. If you press the Pause Switch at this stage, it comes to Pause mode. Brake operates and the Pressure Roller moves away from the Capstan and the Reel Motor stops.

Play mode may be changed to Stop mode by pressing the Stop Switch, and latch of the Head Base being released. The Cassette Case cannot be opened because of the latched eject effect unless it is in Stop mode.

(2) Record Mode

By pressing the Record Switch and the Pause or Play Switch, it may be made to Record mode. The Cam at this moment moves from Stop position to Rec. position. At the same time, Rec. Trigger Mechanism is driven and the Record Switch on the Main P.C.B. is switched on to the Record side. Further, the Cam turns until it comes to the Pause or Play position. On the other hand, the Rec. Trigger Mechanism is released during this process. When the Cam is set in Rec./Pause or Rec./Play position, Record signals will be sent to Bias Oscillating Circuit from Logic Control Circuit to let the Bias to oscillate.

Press the Stop Switch and the Cam comes back to the Stop position. At the same time, it will set the Record Switch on the Main P.C.B. to the Play side.

(3) F.F. or Rewind Mode

By pressing the F.F. or Rewind Switch, it comes either to F.F. or Rewind mode. The only difference of these two modes is that one is to turn the Reel Motor reverse and the other to transmit the torque against the Reel Hub onto the take-up side or to the supply side. Brake is released at this stage and the Reel Motor begins to turn F.F. or Rewind.

(4) Pause Mode

Press the Pause Switch to make it to Pause mode. In changing it from Stop mode to Pause mode, the Brake is first released, then the Head Base is latched, and again the Brake works.

At this stage, the Reel Motor would not turn with the Pressure Roller being apart from the Capstan, and the tape would remain still.

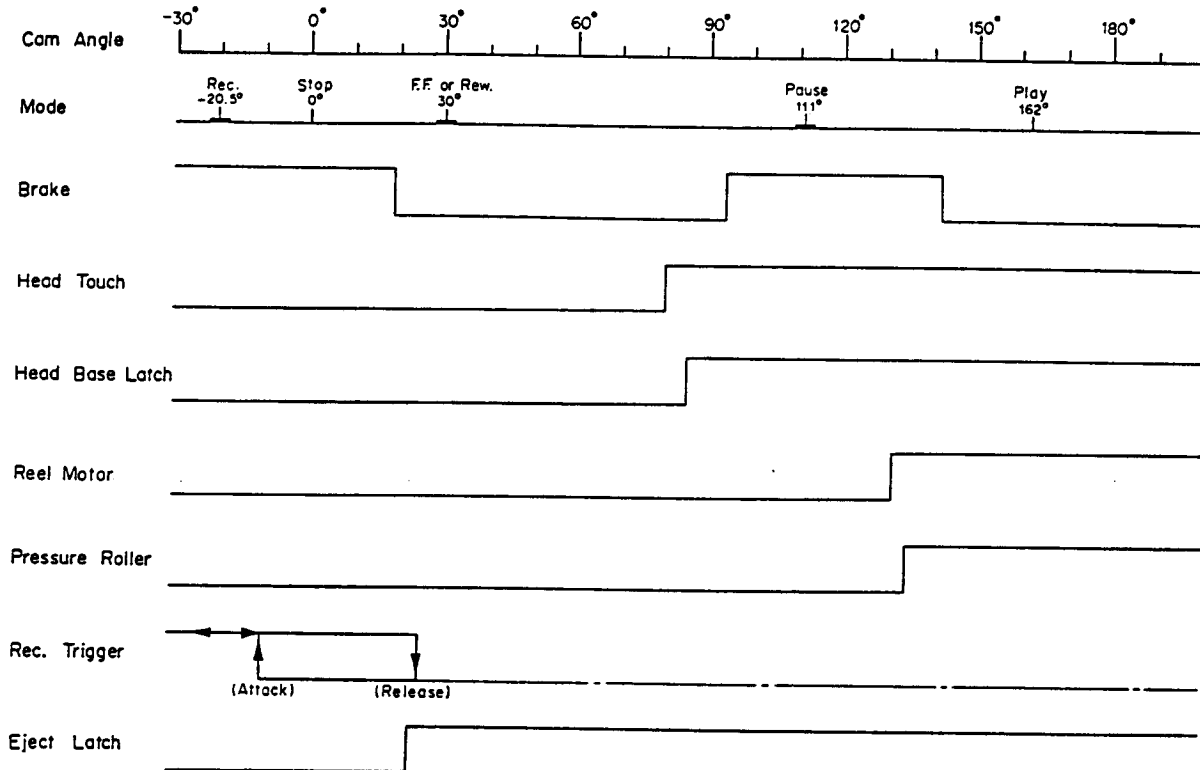

Fig. 2.1.5 Mechanism Control Cam Timing Chart

2.2. Amp. Circuits

2.2.1. Playback Eq. Amp. Circuit

Fig. 2.2.1 shows the playback equalizer circuit, and Fig. 2.2.2 shows the system diagram.

Fig. 2.2.3 shows the time constant of equalizer. The playback head is connected with circuit's input.

Amplifier (Q101 and Q102) is an equalizer amplifier and its time constant is illustrated in Fig. 2.2.3. R111, R112, L101, and C109 compose a peaking circuit. This circuit compensates the gap loss of the playback head so that high-frequency response will be improved.

Playback Eq. Amp. gain is adjusted by semi-fixed volume VR101 (VR201) to obtain 100 mV output level at TP101 (TP201) when 400 Hz Level Tape (DA09005A) is being played back. Equalizer Switch (70 μ s/120 μ s) is connected with Amp. The overall time constants in Playback Eq. Amp. are as follows:

Eq. SW – 70 μ s

3180 μ s (50 Hz) + 70 μ s (2274 Hz)

Eq. SW – 120 μ s

3180 μ s (50 Hz) + 120 μ s (1326 Hz)

Shown below is the table for the position of Tape Switch and Eq. Switch:

Tape SW	Eq. SW	Tape
ZX	70 μ s	Nakamichi ZX
SX	70 μ s	Nakamichi SX, TDK SA, Maxell XL-II, Scotch Master 70 μ s
EX	120 μ s	Low-Noise High-Density (including EX, EXII, TDK AD, Maxell XL-I, Scotch Master 120 μ s)
	70 μ s	Nakamichi EX, EXII

It is specified in the IEC Standard that the time constant is 120 μ s on tapes of ferric oxide, and 70 μ s on tapes of CrO2. However, in the case of Eq. Switch on the N-480, when time constant at playback is changed, at the same time time constant at record must also be changed. Therefore, even though record and playback is made by the method other than the IEC Standard, no deterioration

of frequency response or level difference will occur. (Any other method for instance, record and playback on ferric oxide tape with putting Tape Switch on EX and Eq. Switch on at 70 μ s.) When Nakamichi EX or EXII Tape is used at Tape Switch: EX, and Eq. Switch: 70 μ s, S/N ratio will be improved by approximately 4 dB (WTD).

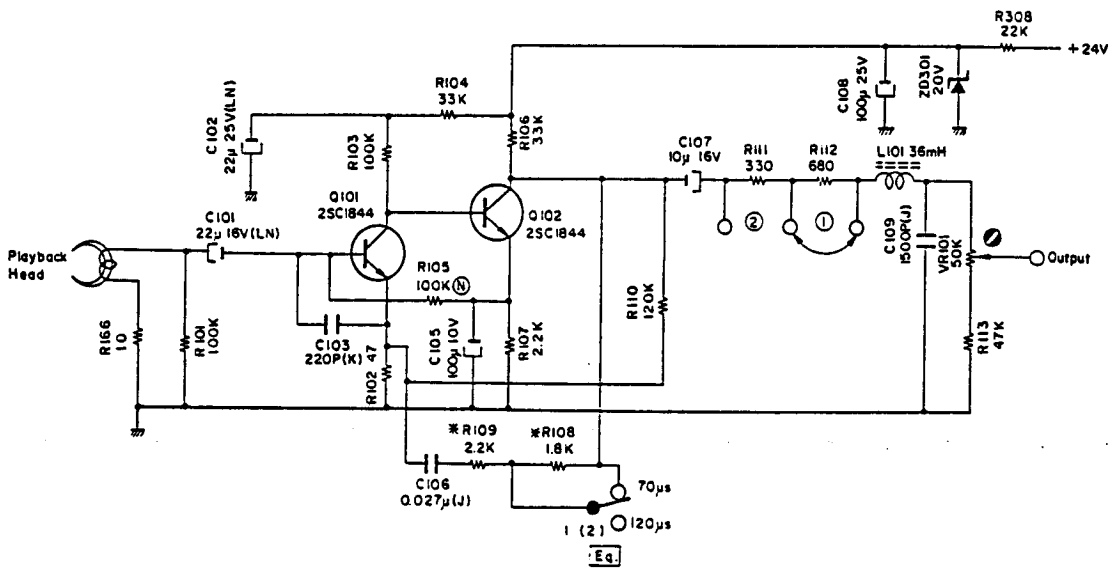

Fig. 2.2.1 Playback Eq. Circuit

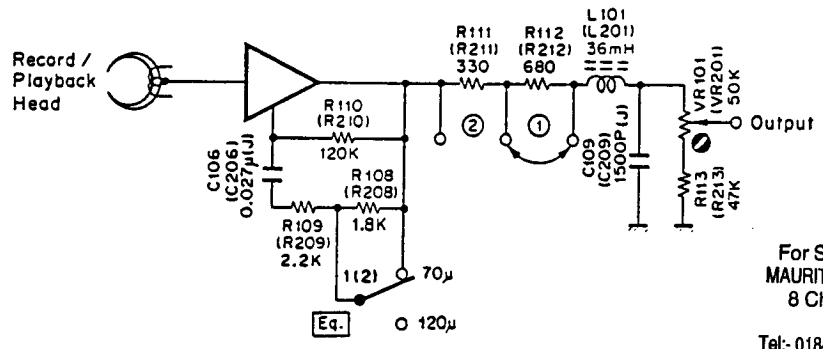

Fig. 2.2.2 System Diagram

For Service Manuals Contact
MAURITRON TECHNICAL SERVICES
 8 Cherry Tree Rd, Chinnor
 Oxon OX9 4QY
 Tel:- 01844-351694 Fax:- 01844-352554
 Email:- enquiries@mauritron.co.uk

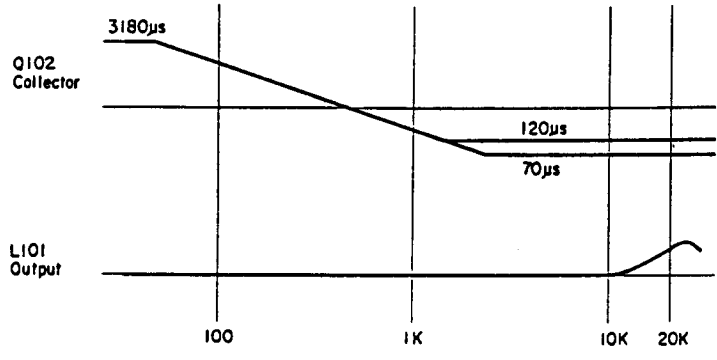

Fig. 2.2.3 Time Constant

2.2.2. Record Equalizer Amplifier Circuit

The record equalizer amplifier circuit consists of the Output Amp. incorporated in the Dolby NR IC and peripheral circuits as shown in Fig. 2.2.4.

VR102, VR103, and VR104 are the record calibration semi-fixed volumes for ZX, SX, and EX tapes. The output of the Output Amp. is given to these volumes, and the outputs from the volumes are fed back to the inverting input of the Output Amp. via amplifier Q103 and a time-constant changeover circuit.

By adjusting L104, compensation for the high frequency range is made by setting a resonance frequency at 21 kHz or neighborhood.

L105, C138 and C139 compose a recording bias trap circuit.

2.2.3. Bias Osc. Circuit

Fig. 2.2.5 shows a push-pull oscillator with an oscillation frequency of 105 kHz which is constructed by capacitors C302 and C303 coupling the collectors and bases of two transistors (Q301 and Q302).

This is used to provide recording bias and as an erase signal.

By pressing the Record and Pause, or Record and Play buttons, (Play + Pause)-Position signal conducted from the logic control circuit becomes H and Q303 turns to ON. Therefore, +24 V is applied to the circuit and oscillation begins.

When the record mode is released, oscillator output is damped by the discharge of C304. This prevents magnetization of the head.

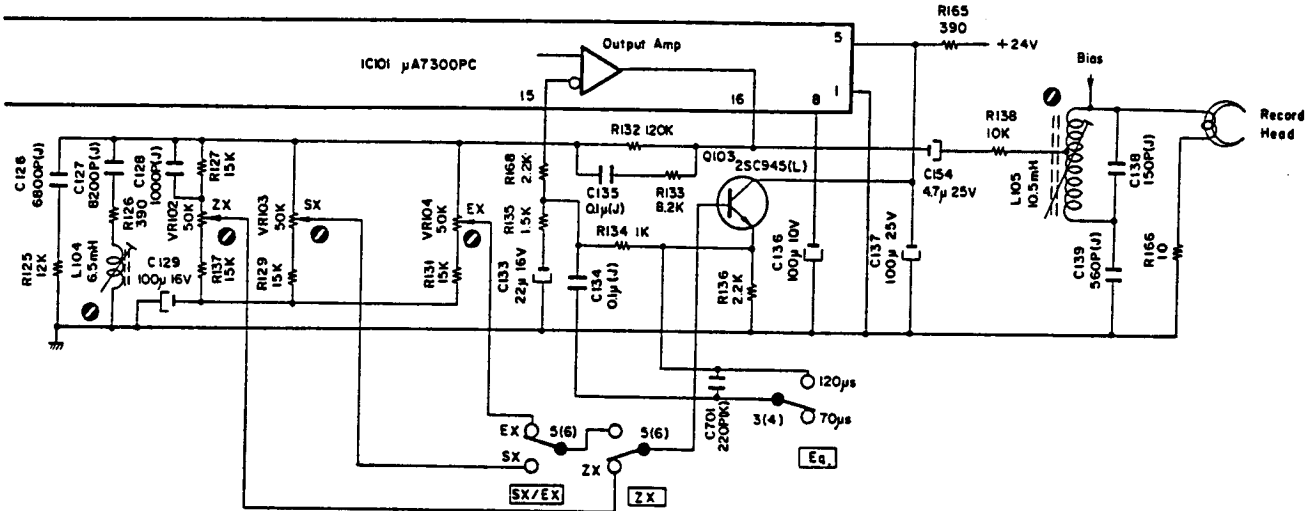

Fig. 2.2.4 Record Eq. Amp. Circuit

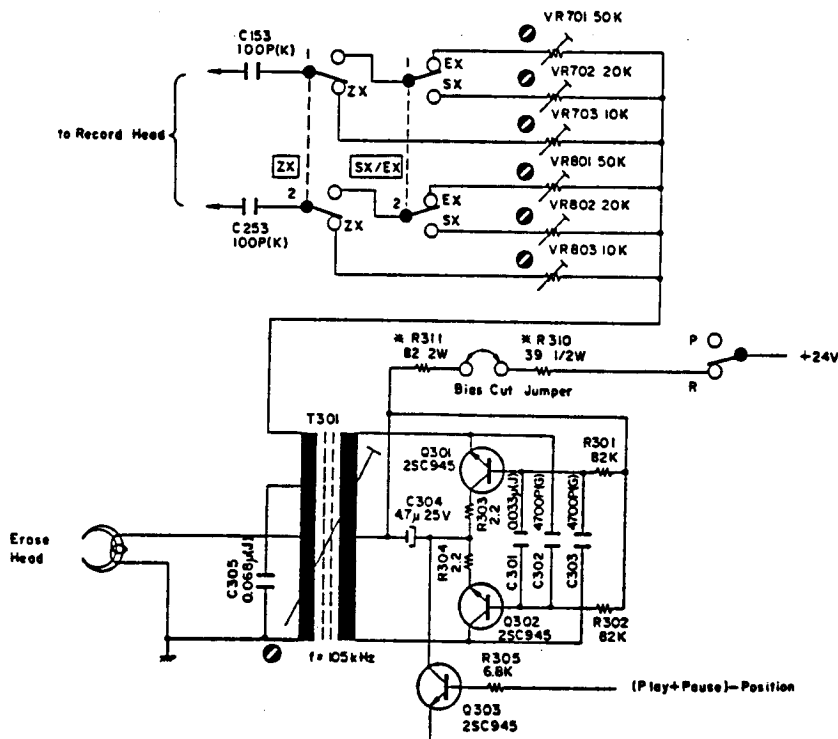

Fig. 2.2.5 Bias Osc. Circuit

2.3. Mechanism Control Circuits

2.3.1. Outline

(1) Control Button Operation

Record, Rewind, Stop, Play, and Fast-Forward Buttons consist of a 5-way switch and are interlocked each other. When one button is pressed, it is mechanically locked in the ON state and other buttons are mechanically released. Stop Button is of momentary type and acts to release other buttons mechanically. But it is not used to control circuits electrically. Pause Button is independent from others and is of push-on and push-off type. Note that if two or more buttons are pressed simultaneously, these buttons are locked in the ON state. Under the normal control button operation, only Record and Play Buttons are pressed simultaneously to set the N-480 in RECORD mode. In this case, both Record and Play Buttons are locked in the ON state and RECORD mode is set. The N-480 is designed so as not to occur erroneous operation even if two or more buttons are pressed simultaneously. Further, to prevent from abnormal tape tension, loosening of tape, etc., the N-480 changes its mode by passing through momentary STOP mode automatically, for example, when PLAYBACK mode is commanded while FF mode, or REW mode is commanded while FF mode.

(2) Auto Shut-off Function

Refer to Fig. 2.3.1 basic circuit diagram.

During FF, REW, or PLAY (PLAYBACK or RECORD)

mode, auto shut-off will be activated when the tape comes to end, and FF, REW, or PLAY mode is changed to STOP mode.

Following explanation is made in regard to REW mode:

In the initial condition, Q428 is turned ON and +24 VS is applied to the emitter of Q402. When Rewind Button is pressed, it is locked in the ON state, as a result, Q402 is turned ON, the REW signal becomes H, and the N-480 is set in REW mode.

When tape-end comes, auto shut-off is activated and Q428 is turned OFF, as a result, +24 VS is shut-off, Q402 is cut off, and the REW signal becomes L. In this way, REW mode is changed to STOP mode. (Note that Rewind Button is still locked in the ON state.) When Play Button is pressed in this state, REW Button is released and Q428 is turned ON, as a result, +24 VS is applied again, Q418 is turned ON, the PLAY signal becomes H, and the N-480 is set in PLAY mode.

(3) Unattended Recording or Playback

Unattended recording or playback is carried out by the use of the lock mechanism of control button, therefore, no special circuit is required for this purpose.

If Record and Play Buttons are pressed, unattended recording can be carried out when the power is connected to the N-480. If only Play Button is pressed, playback will be carried out when the power is connected to the N-480.

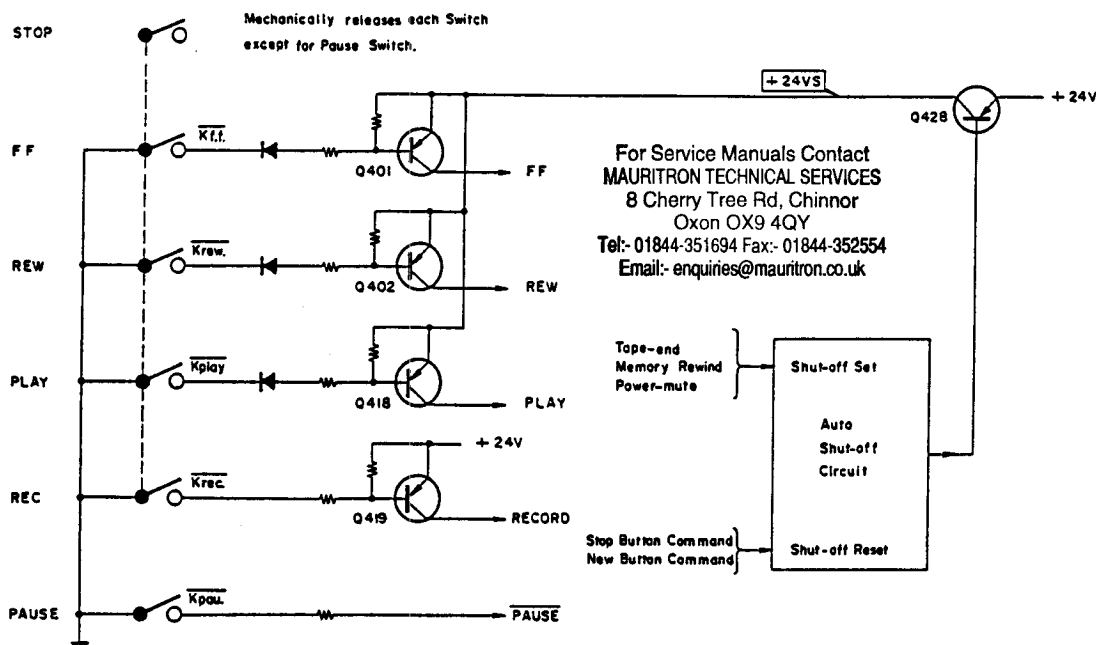

For Service Manuals Contact
MAURITRON TECHNICAL SERVICES
 8 Cherry Tree Rd, Chinnor
 Oxon OX9 4QY
 Tel:- 01844-351694 Fax:- 01844-352554
 Email:- enquires@mauritron.co.uk

Fig. 2.3.1 Basic Auto Shut-off Circuit

2.3.2. +12 V Power Source

Refer to Fig. 2.3.2 circuit diagram. Only +24 V DC power supply is used in the N-480. The circuit acts to produce a +12 V power source from the +24 V DC power supply. Mechanism control is done by using thus produced +12 V.

2.3.3. Power-mute Signal

Refer to Fig. 2.3.3 circuit diagram and Fig. 2.3.4 timing chart. Power-mute = L signal is produced pulse-likely when Power Switch is turned ON or OFF. This L pulse mutes the amp. circuit and also acts to shut off the shut-off circuit initially.

(1) Power Switch ON

Q433 is turned ON at every positive half cycle of the output from the secondary winding of the power transformer. When Q433 is turned ON, C416 is discharged, as a result, the voltage of C416 can not exceed the VBE of Q432, and Q432 is in the cutoff state.

Therefore, the Power-mute = L pulse is produced for a certain period of time when +24 V is built up after Power Switch is turned ON.

The Power-mute = L signal makes Q416 to turn ON, as a result, Mute signal becomes H and the amp. circuit is muted.

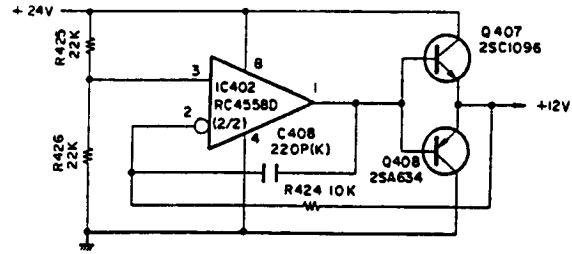

Fig. 2.3.2 +12 V Power Source Circuit

Meanwhile, the Power-mute = L pulse is applied to the shut-off circuit and shut-off is activated.

(2) Power Switch OFF

The output from the secondary winding of the power transformer ceases quickly, and Q433 is turned OFF. Consequently, the base current flows to Q432 through R481, Q432 is turned ON, and the Power-mute signal becomes L.

The Power-mute = L signal makes Q416 to turn ON, as a result, Mute signal becomes H and the amp. circuit is muted. At the same time, shut-off circuit is shut off by the Power-mute = L signal.

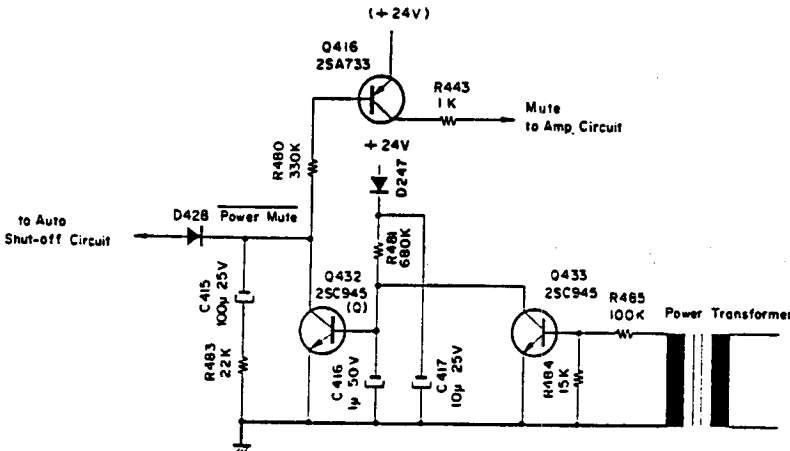

Fig. 2.3.3 Power-mute Circuit

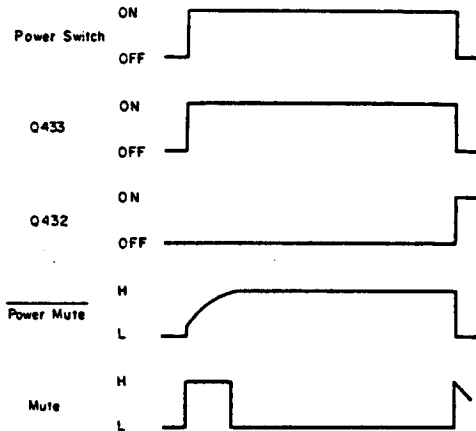

Fig. 2.3.4 Timing Chart

2.3.4. Auto Shut-off Circuit

Refer to Fig. 2.3.5 circuit diagram and Fig. 2.3.6 timing chart.

(1) Shut-off Sensor

Light from lamp PL407 is projected through holes in a disc rotating synchronously with the take-up reel, and the intermittent flashes coming through the disc are converted into electrical signals by a phototransistor Q450. These signals are amplified into square waves, and transmitted to the shut-off detecting circuit in the subsequent stage. When the tape-end comes, the take-up reel and the disc stops rotating, and no pulse is output from the sensor.

(2) Shut-off Detecting Circuit and Peripheral Circuits

Shut-off conditions are as follows:

- reached tape-end during PLAY (PLAYBACK or RECORD), FF, or REW mode
- mode is changed as follows:
 - from FF to REW mode, or vice versa
 - from FF to PLAY mode
 - from RECORD mode to FF or REW mode

When the mode is changed, shut-off is momentarily activated and the mode is changed to STOP mode in a short period of time, and after this STOP mode is over, a new mode is set.

- Power-mute = L pulse is generated when Power Switch is turned ON or OFF
- memory rewind function is activated.

(b) Mode is changed

1) From FF to REW mode, or vice versa, or from FF to PLAY mode

Refer to Fig. 2.3.7 timing chart.

When mode is changed from FF to REW mode, or vice versa, or from FF to PLAY mode, momentary STOP mode is automatically taken in view of the response of the tape deck mechanism, and after this is over, a new mode is set.

The following explains in regard to the case when FF mode is changed to PLAY mode by pressing Play Button during FF mode:

During FF mode, R486 (100 kΩ) is grounded by the $\overline{Kf.f.} = L$ signal. When Play Button is pressed, it is locked ON and FF Button is released. Although FF Button is released, the $\overline{Kf.f.}$ signal is kept L for a short period of time because the delay circuit (C605 and R608) connected in parallel to FF Button acts to prolong the $\overline{Kf.f.} = L$ signal. In this period, the voltage at the point A becomes approx. +22 V from +23 V pulse-likelly as R486 and R488 are grounded by the $\overline{Kf.f.} = L$ and $K_{play} = L$ signals respectively. Consequently, Q424 and Q426 are turned ON, and C411 is charged up to +24 V, but C411 will be discharged after this period is over. The base current to Q430 is supplied from C411 through D424 and R475, as a result, Q430 and Q429 are turned ON, Q428 is turned OFF, and +24 VS is shut off resulting in STOP mode. On the other hand, since the base current to Q427 is supplied from C411 through R469, R427 is turned ON until the discharge of C411 is completed. When the voltage of C411 is lowered than the emitter voltage (approx. 4.2 V) of Q430, Q430 and Q429 are cut off, Q428 is turned ON, and +24 VS is supplied, as a result, the PLAY signal becomes H (+24 VS) and PLAY mode is set.

2) From RECORD mode to FF or REW mode

When mode is changed from RECORD to FF or REW mode, momentary STOP mode is automatically taken in view of the tape deck mechanism, and after this is over, a new mode is set.

When Record Button is released by pressing either FF or REW Button, Q419 is turned from ON to OFF, therefore, a negative differentiated pulse is applied to the point A via C421 (22 μF).

This negative pulse acts to turn ON Q424 and Q426, as a result, C411 is charged up to +24 V. FF or REW mode is set after passing through a certain period of STOP mode in the same manner as above 1).

(c) $\overline{Power-mute} = L$

The $\overline{Power-mute} = L$ pulse is generated when Power Switch is turned ON or OFF. During the $\overline{Power-mute}$ signal is L, the voltage at the point A becomes lower than the emitter voltage of Q424. Subsequently, Q424 and Q426 are turned ON, C411 is charged up to +24 V, and shut-off is activated in the same manner as above (b).

(d) Memory Rewind

During REW mode and with Memory Rewind Sw turned ON, C414 is grounded when the tape counter comes to "999", and Q431 is turned ON pulse-likelly.

As a result, Q430 is turned ON, and shut-off is active resulting in STOP mode.

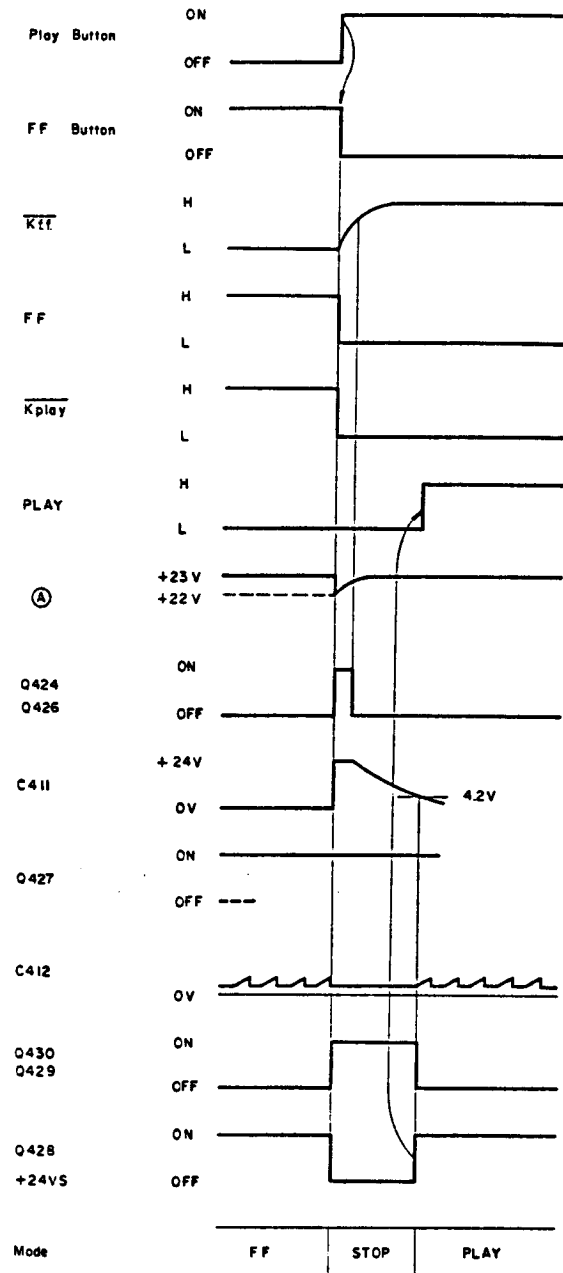

Fig. 2.3.7 Timing Chart

2.3.5. Record Control Circuit

Refer to Fig. 2.3.8 circuit diagram.

RECORD mode is set by pressing Record Button, then Play Button together. By pressing Record Button, the $\overline{\text{Krec}}$ signal becomes L, Q419 is turned ON, Q421 is turned ON, and the record lamp is illuminating. Then, by pressing Play Button further, the $\overline{\text{Kplay}}$ signal becomes L, Q418 is turned ON, the PLAY signal becomes H (+24 VS), and Q420 is turned ON.

Accordingly, the base current flows to Q403 via C406 connected to the base of Q403, and Q403 is turned ON pulse-likely.

The output of Q403 is fed to the control motor drive circuit and acts to bring the cam to the record position.

When Q403 returns to OFF, the cam then moves to the

play position and stays there, thus the mechanism is set to RECORD mode.

Record circuit is designed to protect from the erroneous setting of RECORD mode even if wrong record button operation is made.

Q422 is turned ON during FF or REW mode, or when the cam is set to the play or pause position, i.e., PLAY or PLAY/PAUSE mode. In this case, as D422 is grounded by Q422, Q421 is not turned ON and the record lamp is not lit even if Record Button is further pressed.

Further, the base of Q420 is grounded via D419 and Q422, consequently, Q420 and Q403 are not turned ON and no pulse is output from Q403 to the control motor drive circuit.

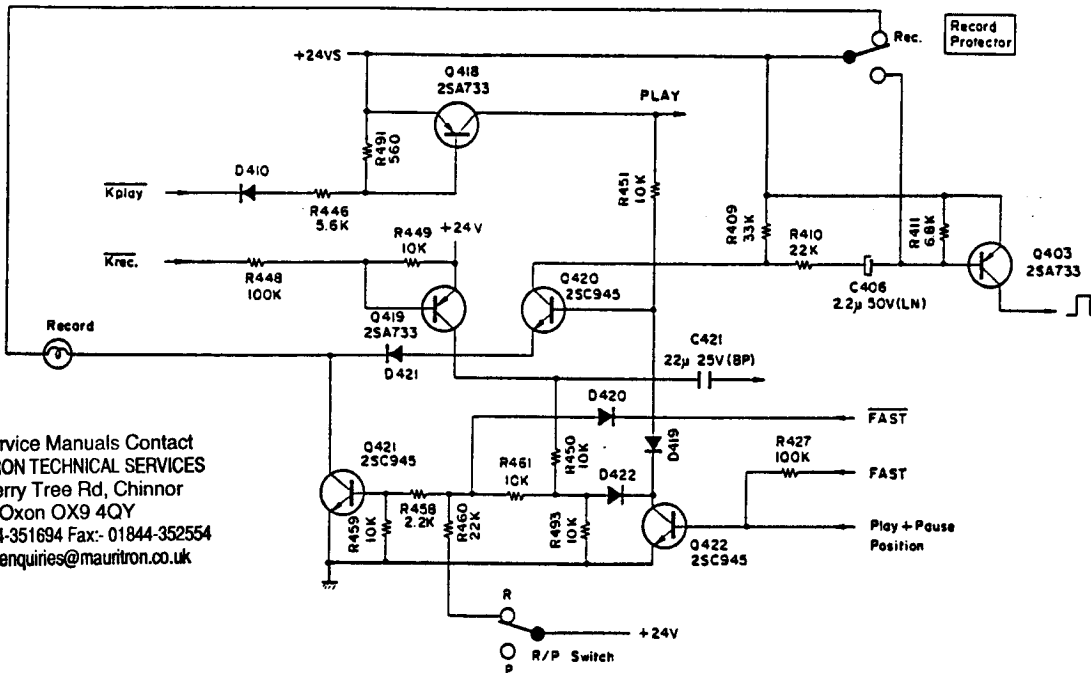

For Service Manuals Contact
MAURITRON TECHNICAL SERVICES
 8 Cherry Tree Rd, Chinnor
 Oxon OX9 4QY
 Tel:- 01844-351694 Fax:- 01844-352554
 Email:- enquiries@mauritron.co.uk

Fig. 2.3.8 Record Control Circuit

2.3.6. Mute Signal

Refer to Fig. 2.3.9 circuit diagram.

When Q416 is turned ON, the Mute = H signal is fed to the amp. circuit and the amp. circuit is muted.

The condition that the amplifier circuit is muted are (Mute = H):

$$Q416 \text{ ON} = ((Q412 \text{ ON}) + \overline{\text{PLAY}}) \cdot (\text{R/P Switch} = \text{Play}) + \text{Power-mute}$$

Power-mute: When Power Switch is turned ON or OFF, Power-mute signal becomes L, i.e., Power-mute signal becomes H, and Q416 is turned ON.

- Q412 ON : Cam is in the pause position.
- Q412 OFF : Cam is in the play position (i.e., PLAYBACK or RECORD mode).

R/P Switch : When R/P Switch on the Main P.C.B. is in the record position, +24 V is applied, but when it is in the play position, no voltage is applied.

The modes in which the amplifier circuit is not muted are (Mute = L):

$$Q416 \text{ OFF} = \overline{Q416 \text{ ON}} \\ = \overline{((Q412 \text{ ON}) \cdot \text{PLAY}) + (\overline{\text{R/P Switch}} = \text{Play}) \cdot \text{Power-mute}} \\ = \overline{((Q412 \text{ OFF}) \cdot \text{PLAY}) + (\text{R/P Switch} = \text{Record}) \cdot \text{Power-mute}}$$

i.e., PLAYBACK mode and RECORD mode.

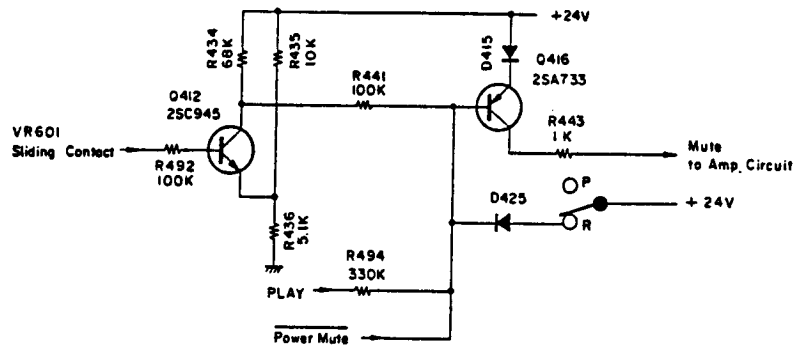

Fig. 2.3.9 Mute Signal Circuit

2.3.7. Control Motor Drive Circuit

Refer to Fig. 2.3.10 circuit diagram and Fig. 2.3.11 timing chart. The control motor is turned by varying amounts, according to which control button is set. This motor is connected to the mechanism control cam, and the mechanism is set to the mode indicated by this cam.

The motor is driven by the differential amplifier IC402 (1/2) and drivers Q405 and Q406. In the control motor stop condition, both voltages at pins No.5 (non-inverting input) and No.6 (inverting input) of IC402 (1/2) are equal and the difference of both inputs is zero. When a new mode is demanded, the balance of both inputs is broken, as a result, the control motor is driven until both inputs are balanced. The cam control variable resistor VR601 moves synchronously with the motor so that the voltage at the sliding contact of VR601 is changed.

When the voltage at the sliding contact of VR601 is changed and the input difference of the differential

amplifier IC402 (1/2) becomes zero, the control motor stops.

The following table shows the relationship between cam position and the voltage at the sliding contact of the cam control variable resistor VR601, and the state of transistors in each mode.

Position on Cam	Typical Voltage at Sliding Contact of Cam Control Volume
Record	16V
Stop	15V
FF/REW	13.5V
Pause	10V
Play	7.5V

Mode	ON		OFF	
	Record	Q403, Q410	Q412	Q404
Stop		Q412	Q403, Q404, Q410	Q411
FF/REW	Q404, Q410	Q412	Q403	Q411
Play-Pause	D417 ON	Q411, Q412	Q403, Q404, Q410	
Play		Q411	Q403, Q404, Q410	Q412

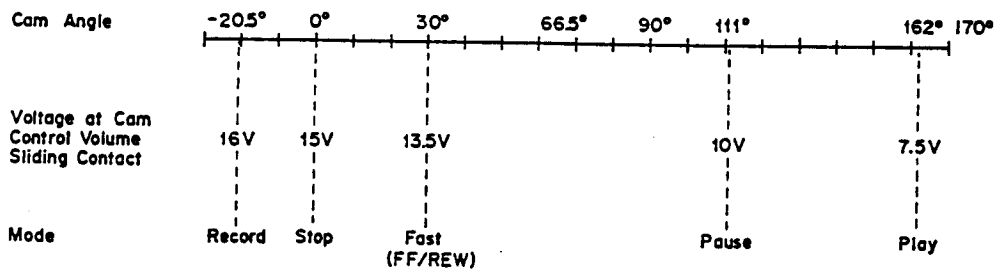

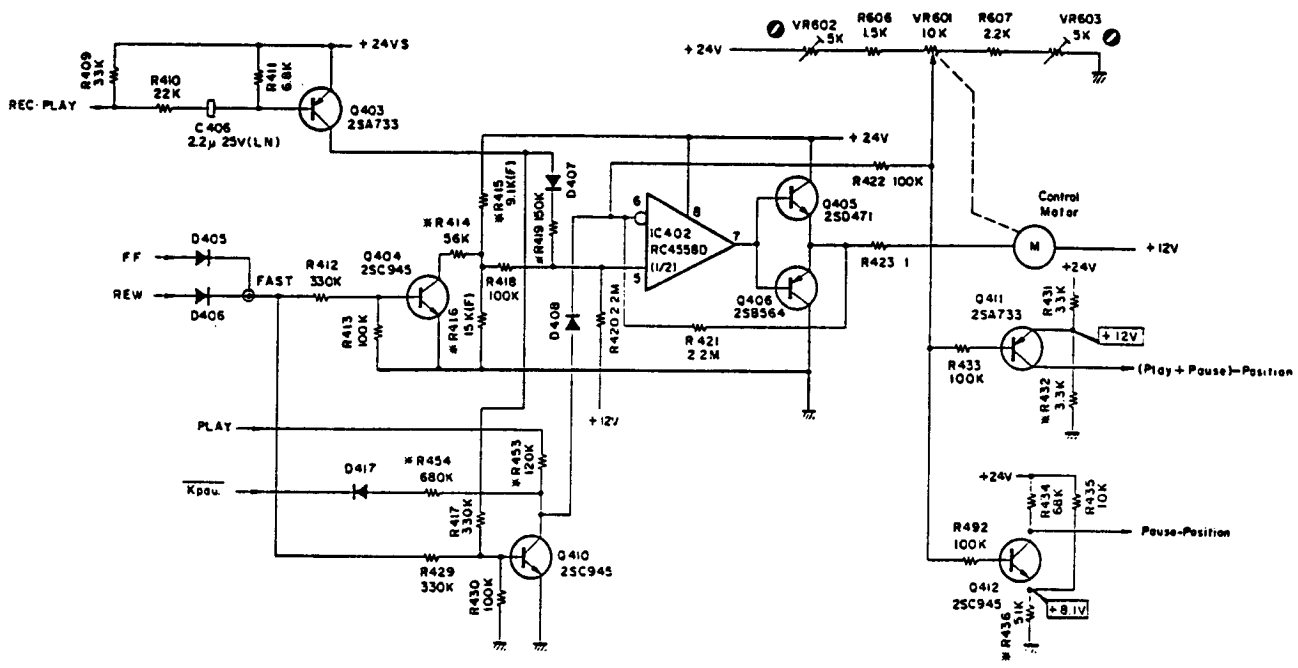
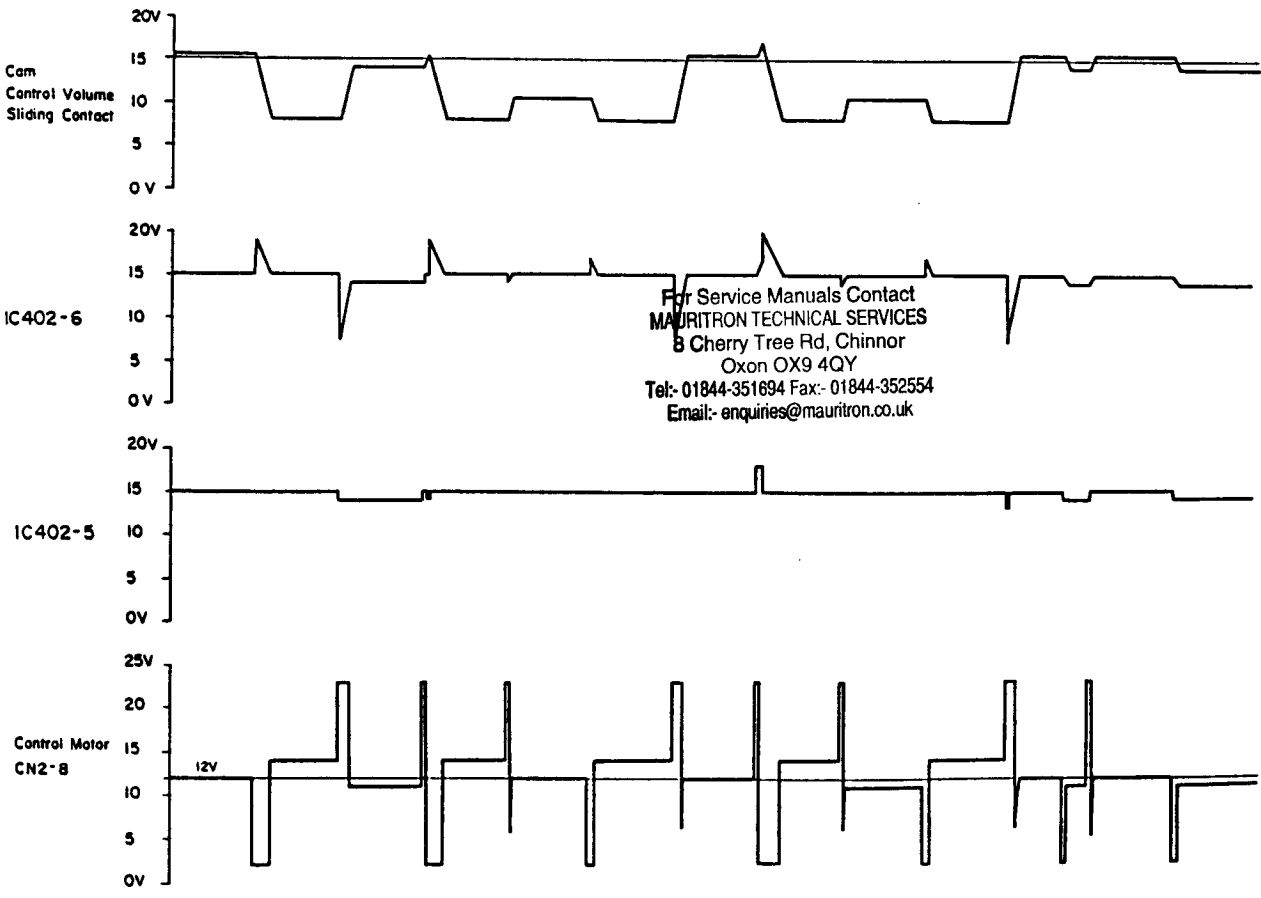

Fig. 2.3.10 Control Motor Drive Circuit

Control Button	STOP	PLAY	FF(REW)	PLAY	PLAY/PAUSE	PLAY	STOP	REC/PLAY	REC/PLAY PAUSE	REC/PLAY	FF(REW)	STOP	FF(REW)
Mode	STOP	PLAY	FF(REW)	PLAY	PLAY PAUSE	PLAY	STOP	REC. PLAY	REC.PLAY PAUSE	REC. PLAY	STOP	STOP	FF(REW)



For Service Manuals Contact
 MAURITRON TECHNICAL SERVICES
 8 Cherry Tree Rd, Chinnor
 Oxon OX9 4QY
 Tel: 01844-351894 Fax: 01844-352554
 Email: enquiries@mauritron.co.uk

Fig. 2.3.11 Timing Chart

2.3.8. Reel Motor Governor

Refer to Fig. 2.3.12 circuit diagram.

One end of the reel motor is connected with +12 V and the other end is a terminal for controlling.

During FF mode, Q413 is turned ON and the reel motor is grounded. Accordingly, the reel motor turns in the direction of fast-forwarding. On the other hand, during REW mode, +24 V (REW = H) is applied to the reel motor and the reel motor turns in the direction of rewinding. During PLAY (PLAYBACK or RECORD) mode, Q412 is turned OFF and the Pause-position signal becomes H, as a result, Q417 is turned OFF and the reel motor is turned at a constant speed by the governor composed of Q414 and

Q415.

During PLAY/PAUSE mode, Q412 is turned ON and the Pause-position signal becomes L, therefore, Q417 is turned ON, Q414 is biased in the reverse direction, and Q414 is cut off, thus the reel motor does not turn.

Take-up function at loading:

When a cassette tape is inserted and loaded, Eject Switch will become open. Consequently, the base current is applied to Q413 through C409, and Q413 is turned ON pulse-likely. During Q413 is turned ON, the reel motor turns in the direction of fast-forwarding and eliminates tape loosening of the cassette tape if any.

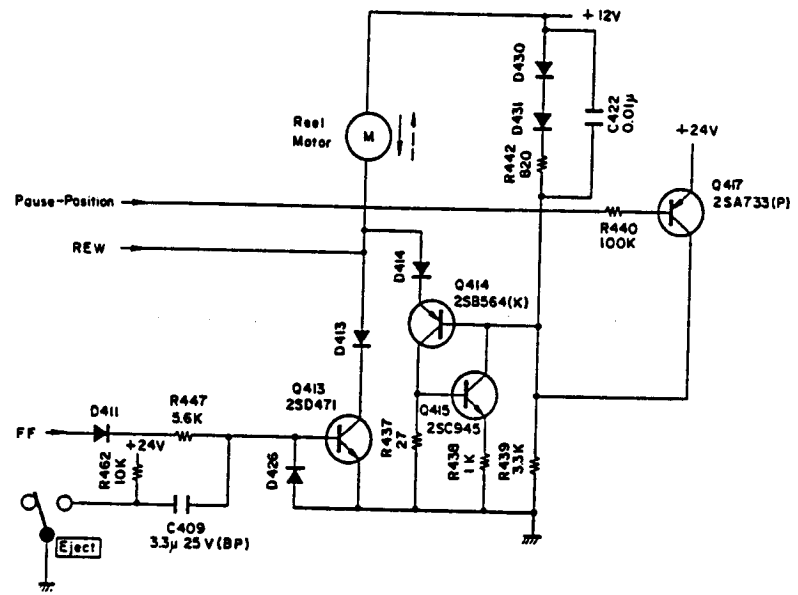

Fig. 2.3.12 Reel Motor Governor

3. REMOVAL PROCEDURES

3.1. Cassette Case Cover Ass'y

Refer to Fig. 3.1.

- (1) Press the Eject Button to open the Cassette Case Ass'y.
- (2) Pull out F01 (Cassette Case Cover Ass'y) upwardly.

3.2. Top Cover Ass'y

Refer to Fig. 3.1.

Remove F02 and F03, then disassemble F04 (Top Cover Ass'y).

3.3. Bottom Cover Ass'y

Refer to Fig. 3.1.

Remove F05, then disassemble F06 (Bottom Cover Ass'y).

3.4. Front Panel Ass'y

Refer to Fig. 3.2.

- (1) Refer to Fig. 3.1. Remove Top Cover Ass'y and Bottom Cover Ass'y referring to items 3.2 and 3.3.
- (2) Pull out F01 (Volume Knobs).
- (3) Remove F02 (Power Switch Joint Bar) by releasing the self-interlocking pin of the Power Switch Joint Bar from Power Switch, and turn F02 (Power Switch Joint Bar) by 90° either clockwise or counterclockwise, then disassemble F02 (Power Switch Joint Bar) from the Power Switch Knob Ass'y.
- (4) Remove F03, then disassemble F04 (Front Panel Ass'y).

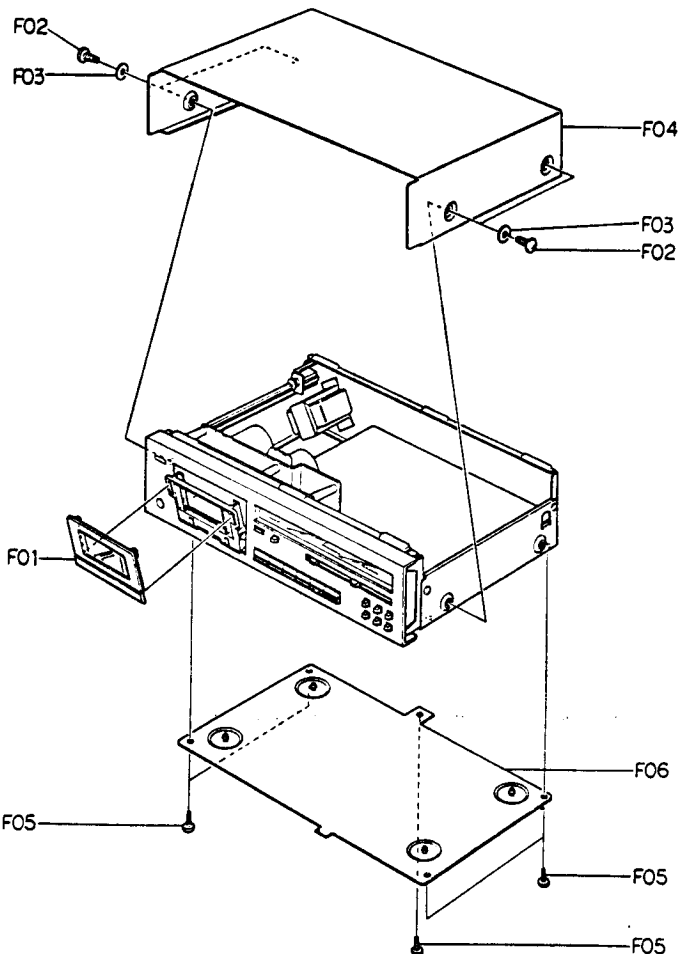

Fig. 3.1

3.5. Headphone Jack Ass'y

Refer to Fig. 3.2.

- (1) Remove Front Panel Ass'y referring to item 3.4.
- (2) Remove F05, then disassemble F06 (Headphone Jack Ass'y).

3.6. Mechanism Ass'y

Refer to Fig. 3.2.

- (1) Remove Front Panel Ass'y referring to item 3.4.
- (2) Remove F07 and F08, then disassemble F09 (Mechanism Ass'y including 4 connectors and a record switch linkage).

3.7. Meter Ass'y

Refer to Fig. 3.2.

- (1) Remove Front Panel Ass'y referring to item 3.4.
- (2) Remove F10 (Meter Ass'y) by releasing self-interlocking pins of the Meter Ass'y.

3.8. Lamp P.C.B. R Ass'y and Lamp P.C.B. L Ass'y

Refer to Fig. 3.2.

- (1) Remove Meter Ass'y referring to item 3.7.
- (2) Remove F11 (Lamp P.C.B. R Ass'y) and F12 (Lamp P.C.B. L Ass'y) by releasing the self-interlocking pins.

For Service Manuals Contact
MAURITRON TECHNICAL SERVICES
 8 Cherry Tree Rd, Chinnor
 Oxon OX9 4QY
 Tel:- 01844-351694 Fax:- 01844-352554
 Email:- enquiries@mauritron.co.uk

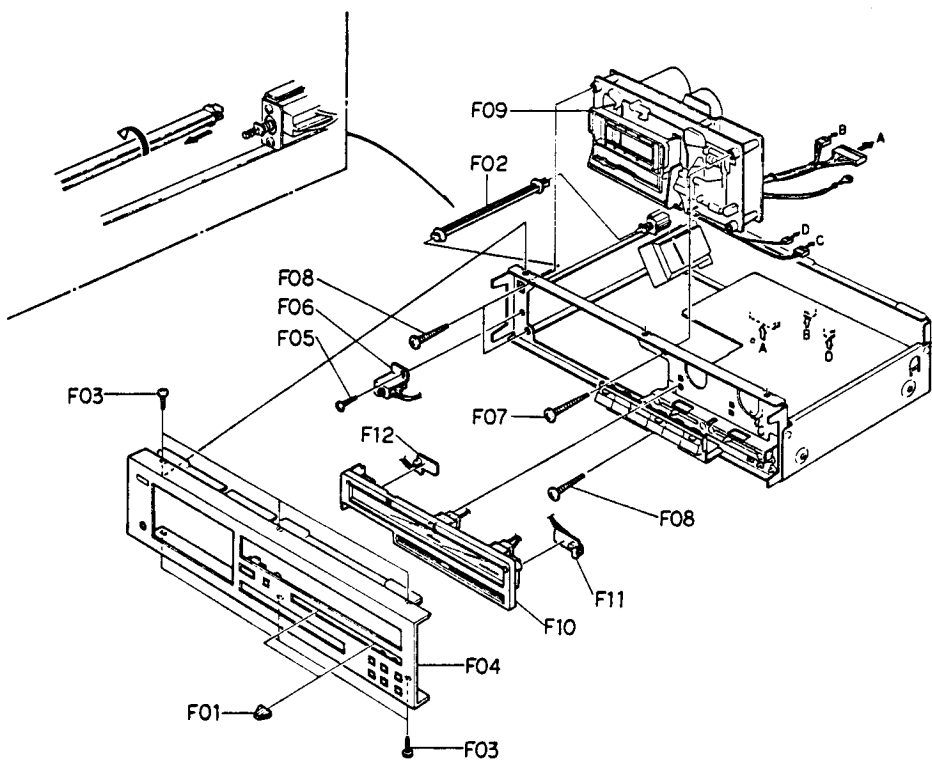

Fig. 3.2

3.9. Main P.C.B. Ass'y

Refer to Fig. 3.3.

- (1) Refer to Fig. 3.2. Remove Front Panel Ass'y referring to item 3.4.
- (2) Remove 4 connectors and the wires connected by wrapping from the F05 (Main P.C.B. Ass'y).
- (3) Remove F01, F02, F03, F04 and the Record Switch Linkage from the Wire Holder assembled with Record Switch, then disassemble F05 (Main P.C.B. Ass'y).

3.10. Control Switch Holder Ass'y

Refer to Fig. 3.3.

- (1) Refer to Fig. 3.2. Remove Meter Ass'y referring to item 3.7.
- (2) Remove F06, then disassemble F07 (Control Switch Holder Ass'y).

3.11. Switch P.C.B. Ass'y

Refer to Fig. 3.3.

- (1) Refer to Fig. 3.2. Remove Front Panel Ass'y referring to item 3.4.
- (2) Remove F08, then disassemble F09 (Switch P.C.B. Ass'y).

3.12. Volume P.C.B. Ass'y and Control Switch P.C.B. Ass'y

Refer to Fig. 3.3.

- (1) Remove Control Switch Holder Ass'y referring to item 3.10.
- (2) Remove F10, then disassemble F11 (Volume P.C.B. Ass'y).
- (3) Remove F12, then disassemble F13 (Control Button Spring).
- (4) Remove F14 (Control Button Shaft), then disassemble F15 (Control Buttons).
- (5) Remove F16, then disassemble F17 (Control Switch P.C.B. Ass'y).

3.13. Rear Panel Ass'y, Power Transformer and Power Switch

Refer to Fig. 3.4.

- (1) Refer to Fig. 3.1. Remove Top Cover Ass'y and Bottom Cover Ass'y referring to items 3.2 and 3.3.
- (2) Remove F01, F02 and F03, then disassemble F04 (Rear Panel Ass'y).
- (3) Remove F05 and F06, then disassemble F07 (Power Transformer).
- (4) Remove Power Switch Joint Bar by releasing the self-interlocking pin of the Power Switch Joint Bar from Power Switch and F08, then disassemble F09 (Power Switch Holder Ass'y).
- (5) Remove F10, then disassemble F11 (Power Switch).

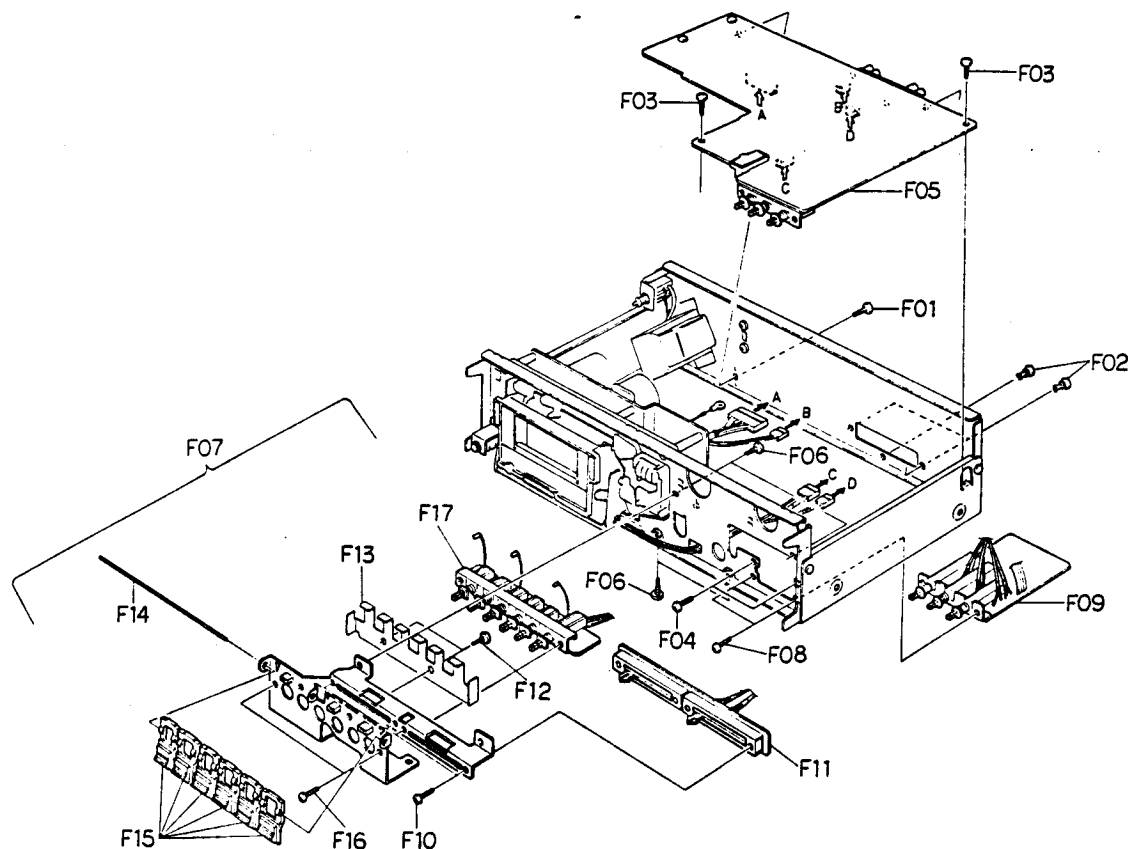

Fig. 3.3

3.14. Cassette Case Ass'y and Cover Plate Ass'y

Refer to Fig. 3.5.

- (1) Refer to Fig. 3.2. Remove Mechanism Ass'y referring to item 3.6.
- (2) Press the Eject Button to open the Cassette Case Ass'y.
- (3) Remove F01, then disassemble the piston of the Pneumatic Damper Ass'y.
- (4) Remove F02 and F03 (Cassette Case Holder L Ass'y), then disassemble F04 (Cassette Case Ass'y).

- (5) Remove F05, then disassemble F06 (Cover Plate Ass'y).

3.15. Tape Counter Ass'y

Refer to Fig. 3.5.

- (1) Refer to Fig. 3.2. Remove Meter Ass'y referring to item 3.7.
- (2) Remove F07, then disassemble F08 (Tape Counter Ass'y).

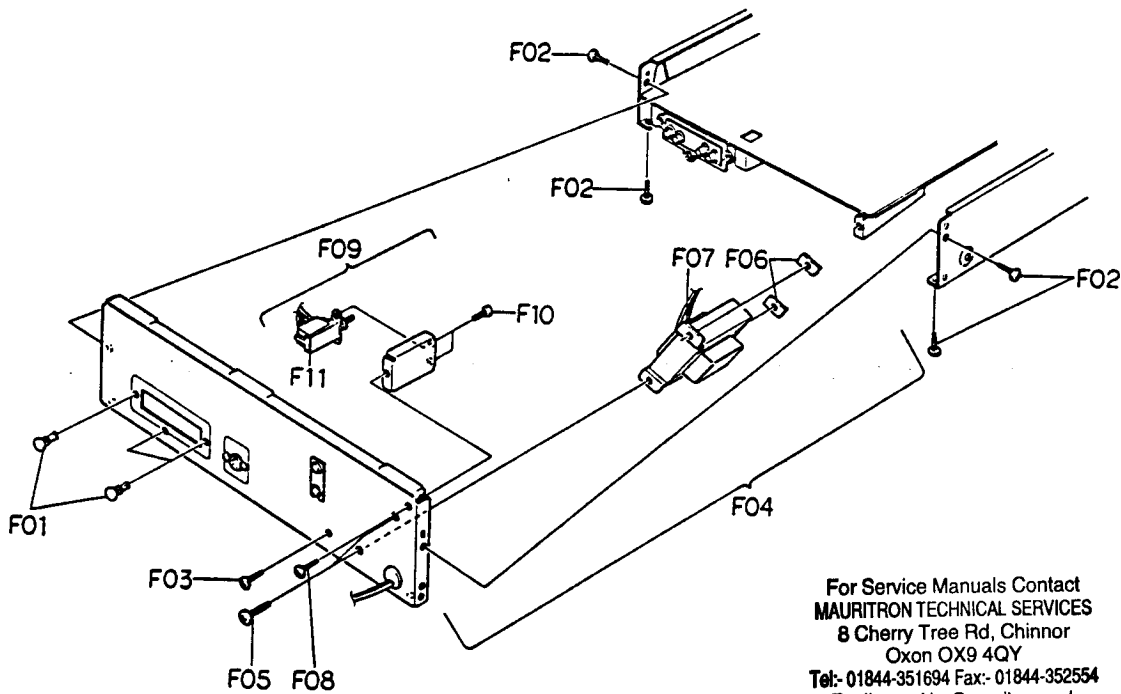

For Service Manuals Contact
MAURITRON TECHNICAL SERVICES
8 Cherry Tree Rd, Chinnor
Oxon OX9 4QY
Tel: 01844-351694 Fax: 01844-352554
Email: enquiries@mauritron.co.uk

Fig. 3.4

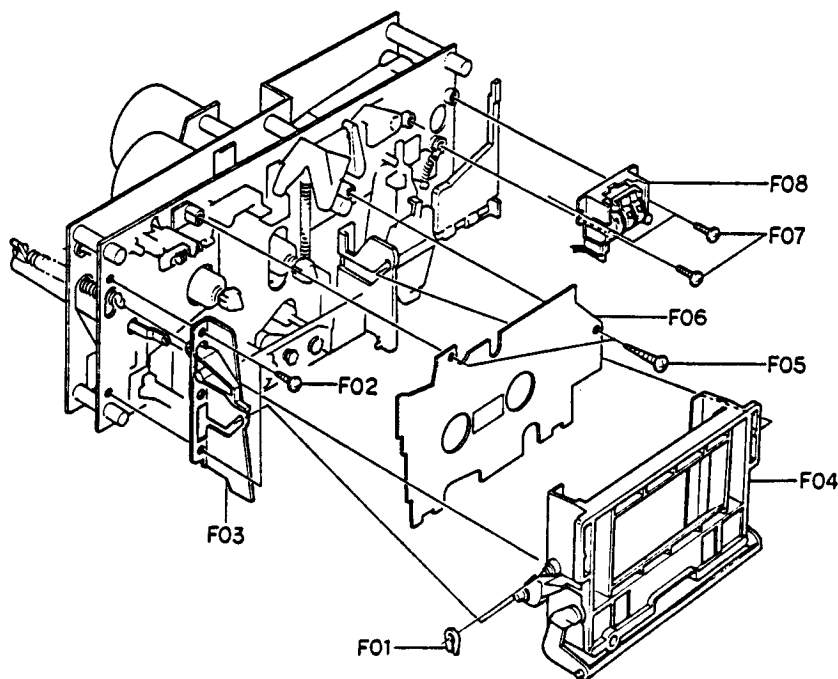

Fig. 3.5

3.16. Capstan Motor Ass'y and Flywheel Ass'y

Refer to Fig. 3.6.

- (1) Refer to Fig. 3.2. Remove Mechanism Ass'y referring to item 3.6.
- (2) Remove F01 and F02, then disassemble F03 (Flywheel Holder Ass'y) and F08 (Capstan Belt).
- (3) Remove F04, then disassemble F05 (Capstan Motor Ass'y).
- (4) Remove F06, then disassemble F07 (Control P.C.B. Ass'y).
- (5) Remove F09 (Supply Flywheel Ass'y), then disassemble F10 (Take-up Flywheel Ass'y).
- (6) After removing both Flywheel Assemblies, disassemble F11 (Thrust Washer 3 mm), F12 (Thrust Washer 2.6 mm), F13 (Flange Thrust Caps) and F14 (Thrust Springs).

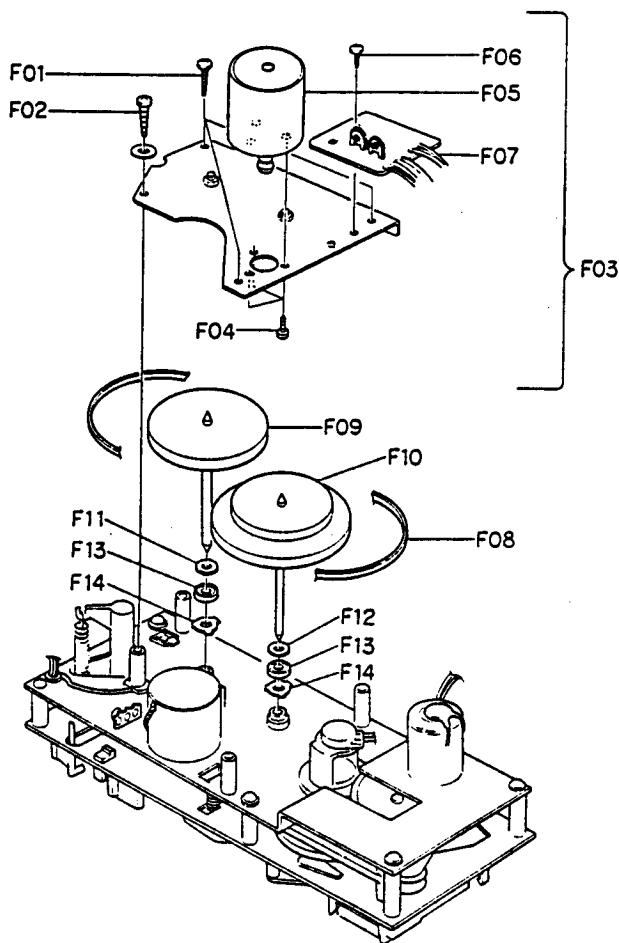

Fig. 3.6

3.17. Sub Mechanism Chassis Ass'y

Refer to Fig. 3.7.

- (1) Refer to Fig. 3.6. Remove Flywheel Assemblies referring to item 3.16.
- (2) Remove F01 and F02, then disassemble F03 (Sub Mechanism Chassis Ass'y).

3.18. Control Motor Ass'y and Reel Motor Ass'y

Refer to Fig. 3.7.

- (1) Remove Sub Mechanism Chassis Ass'y referring to item 3.17.
- (2) Remove F04, then disassemble F05 (Control Motor Ass'y).
- (3) Remove F06, then disassemble F07 (Reel Motor Ass'y).

3.19. Cam Control Volume

Refer to Fig. 3.7.

- (1) Remove Sub Mechanism Chassis Ass'y referring to item 3.17.
- (2) Remove F08, then disassemble F09 (Volume Coupler).
- (3) Remove F10, then disassemble F11 (Cam Control Volume).

3.20. Reel Hub Ass'y and Idler Ass'y

Refer to Fig. 3.7.

- (1) Remove Sub Mechanism Chassis Ass'y referring to item 3.17.
- (2) Remove F12 (Reel Hub Heads), then disassemble F13 (Reel Hub B Assemblies), F14 (Reel Hub Take-up Ass'y), F15 (Reel Hub Supply Ass'y), F16 (Back Tension Ass'y) and F17 (Back Tension Spring).
- (3) Remove F18, then disassemble F19 (Idler Ass'y).

3.21. Cam Drive Gear and Control Cam

Refer to Fig. 3.7.

- (1) Remove Sub Mechanism Chassis Ass'y referring to item 3.17.
- (2) Remove F20, then disassemble F21 (Cam Drive Gear).
- (3) Remove F22, then disassemble F23 (Counter-Load Arm Ass'y).
- (4) Remove F24, then disassemble F25 (Control Cam).

3.22. Head Mount Base Ass'y

Refer to Fig. 3.8.

- (1) Refer to Fig. 3.5. Remove Cassette Case Ass'y referring to item 3.14.
- (2) Remove F01, then disassemble F02 (Head Mount Base Ass'y).

3.23. Pressure Roller Ass'y and Erase Head

Refer to Fig. 3.8.

- (1) Remove Head Mount Base Ass'y referring to item 3.22.
- (2) Remove F03 and a washer, then disassemble F04 (Supply Pressure Roller Ass'y).
- (3) Remove F05, then disassemble F06 (Erase Head).
- (4) Remove F07 and a washer, then disassemble F08 (Take-up Pressure Roller Ass'y).

3.24. Record/Playback Head Ass'y

Refer to Fig. 3.8.

- (1) Remove Head Mount Base Ass'y referring to item 3.22.
- (2) Turn F09 by 90° by pushing it, then disassemble F10 (Record/Playback Head Ass'y).

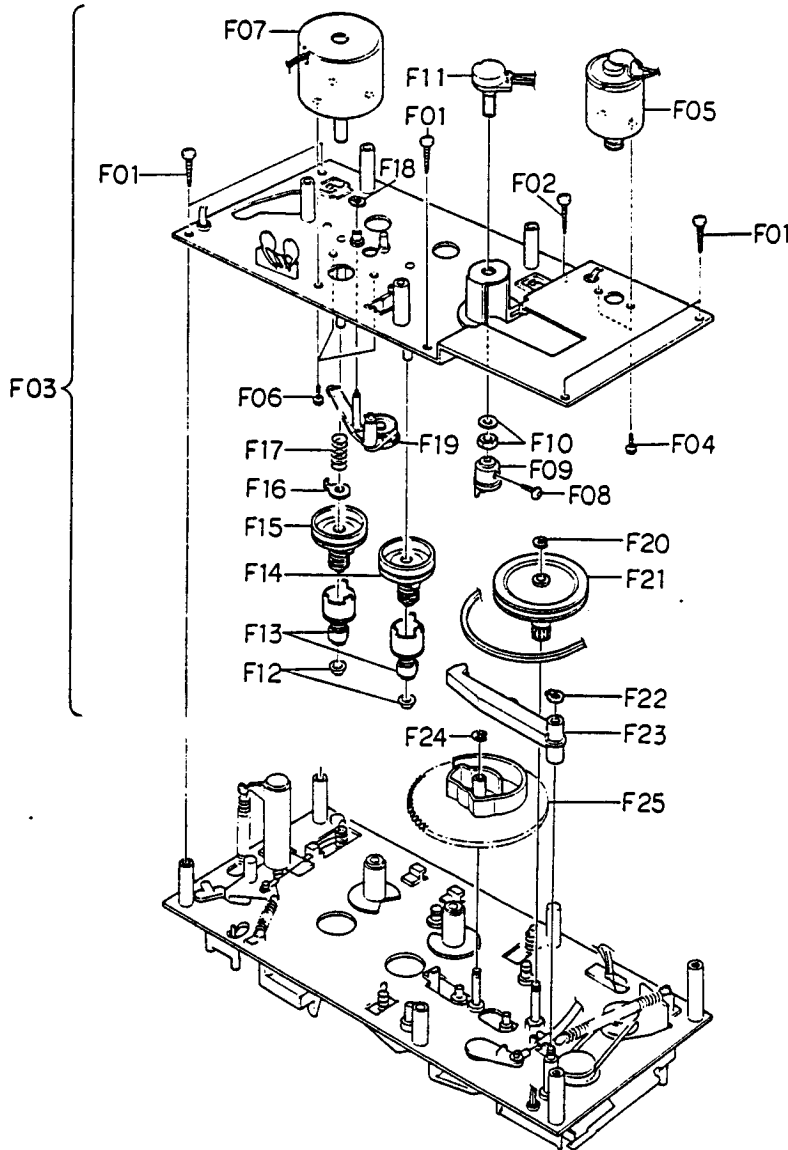

Fig. 3.7

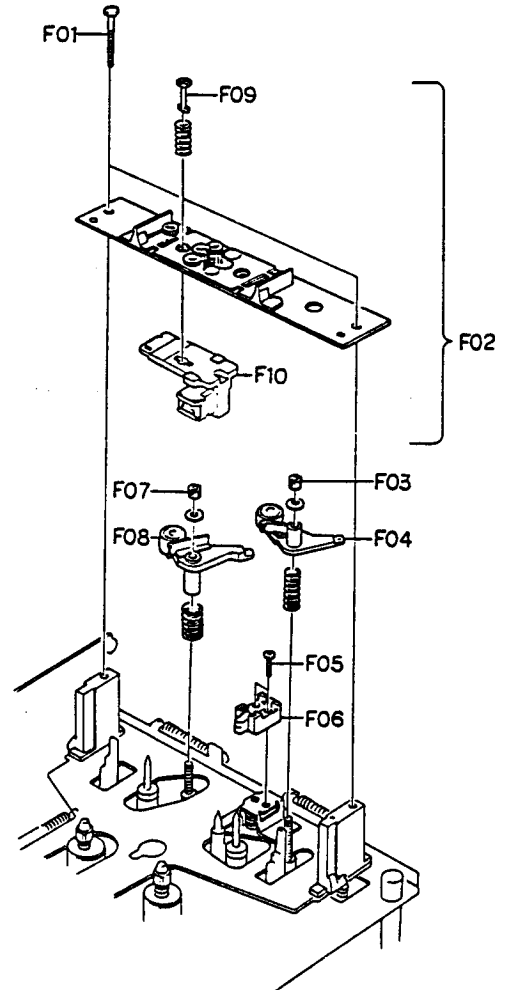

Fig. 3.8

For Service Manuals Contact
MAURITRON TECHNICAL SERVICES
 8 Cherry Tree Rd, Chinnor
 Oxon OX9 4QY
 Tel:- 01844-351694 Fax:- 01844-352554
 Email:- enquiries@mauritron.co.uk

4. MEASUREMENT INSTRUMENTS

- (1) Audio Generator (20 Hz – 200 kHz)
- (2) AC Millivolt Meter (with dB measures)
- (3) Oscilloscope (DC – 5 MHz)
- (4) Distortion Meter
- (5) Speed & Wow/Flutter Meter
- (6) Frequency Counter (DC – 1 MHz)
- (7) Ohm Meter
- (8) DC Volt Meter
- (9) AC Volt Meter
- (10) Torque Gauge (DA09013A)
- (11) 15 kHz Azimuth Tape (DA09004A)
- (12) 3 kHz Speed & Wow/Flutter Tape (DA09006A)
- (13) 1 kHz Track Alignment Tape (DA09007A)
- (14) 400 Hz Level Tape (DA09005A)
- (15) 20 kHz PB Frequency Response Tape (DA09001A)
- (16) 15 kHz PB Frequency Response Tape (DA09002A)
- (17) 10 kHz PB Frequency Response Tape (DA09003A)
- (18) Reference EXII Tape (DA09021A)
- (19) Reference SX Tape (DA09025A)
- (20) Reference ZX Tape (DA09037A)
- (21) Tilt Check Gauge M-9036 (DA09036A)
- (22) Stroke Check Gauge M-9038 (DA09038A)
- (23) EH Tilt Check Gauge M-9040 (DA09040A)
- (24) EH Stroke Check Gauge M-9042 (DA09042A)
- (25) EH Stroke Check Gauge M-9051 (DA09051A)
- (26) Audio Analyzer T-100
(including Distortion, Wow/Flutter, Speed, Oscillator and dB meter)

Notes: 1. (10) – (26) are the products of Nakamichi Corporation.
 2. EH Stroke Check Gauge M-9042 (DA09042A) should be used for the Models from serial Nos. A304.501001 to A304.516073, and EH Stroke Check Gauge M-9051 (DA09051A) is for the Models bearing serial Nos. A304.516074 and greater.

For Service Manuals Contact
MAURITRON TECHNICAL SERVICES
 8 Cherry Tree Rd, Chinnor
 Oxon OX9 4QY
 Tel:- 01844-351694 Fax:- 01844-352554
 Email:- enquiries@mauritron.co.uk

5. MECHANICAL ADJUSTMENTS

5.1. Mechanism Control Cam Adjustment

Before Adjustment, disassemble the Front Panel Ass'y then remove the Cover Plate Ass'y, referring to items 3.4 and 3.14.

(1) Offset Adjustment of Control Motor Driver

(a) Refer to Figs. 5.1 and 5.2.

Adjust VR602 and VR603 on the Control P.C.B. to locate approximately at the middle of the variable range. Then turn ON the Power Switch.

VR602 (for Cam position stop)

VR603 (for Cam position play)

(b) Press the Stop Switch to set the N-480 in stop mode. Adjust VR602 (for stop) so that the "S" mark on the Cam corresponds to the pointer on the mechanism chassis.

(c) Press the Play Switch to set the N-480 in playback mode.

(Cam will rotate, and the position marked with "PY" comes to the pointer.) Adjust VR603 (for play) so that the "PY" mark on the Cam corresponds to the pointer.

(d) Repeat above (b) and (c) 2 - 3 times so that the "S" and "PY" marks on the Cam correspond to the pointer accurately in stop and playback modes respectively.

(This adjustment is required because the position adjusted by one volume will be slightly changed when the other volume is adjusted.)

(e) Set the N-480 in FF, pause, or record mode by pressing each switch and check to insure that the pointer is in a range of "F", "PS", or "R" mark respectively.

(f) If out of the range, precise adjustment for each position according to "(2) Offset Fine Adjustment of Control Motor Driver" will be required.

(2) Offset Fine Adjustment of Control Motor Driver

Adjust only if a satisfactory result is not obtained in "(1) Offset Adjustment of Control Motor Driver". This adjustment is made by changing the value of the fixed resistors on the Main P.C.B.

Note: The value of voltage is typical value.

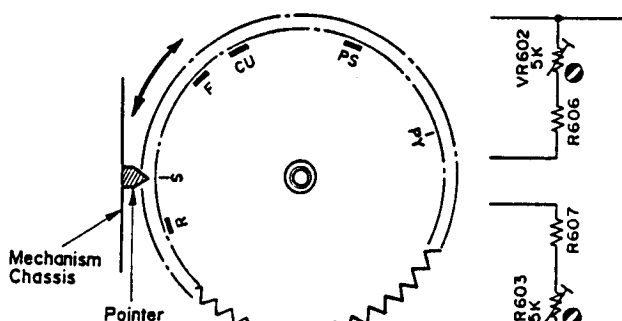

Fig. 5.1

Fig. 5.2

(a) Observation Point of Reference Voltage

Observe the each voltage at the sliding contact of the Cam Control Volume VR601 (10 k Ω) in stop, fast (FF or REW), pause, record and playback modes.

Note: When Record and Play Switches are pressed to set N-480 in record mode, the Cam is first set to the record position in a short period of time then stays at the play position.

Therefore to keep the Cam at the record position, following procedure is required:

Short the both leads of capacitor C406 (2.2 μ F) on the Main P.C.B. with a jumper wire, then press the Record and Play Switches.

(b) Reference Voltage

Reference voltage at the sliding contact of VR601 (Cam Control Volume) in each mode is as follows:

Mode	Reference Voltage (Typical Value)
Record	16 V $\left\{ \begin{array}{l} 1 \text{ V } +0.4 \text{ V} \\ -0.2 \text{ V} \end{array} \right.$
Stop	15 V $\left\{ \begin{array}{l} 1.5 \text{ V } \pm 0.25 \text{ V} \end{array} \right.$
Fast (FF/REW)	13.5 V $\left\{ \begin{array}{l} 1.5 \text{ V } \pm 0.25 \text{ V} \end{array} \right.$
Pause	10 V $\left\{ \begin{array}{l} 2.5 \text{ V } \pm 0.4 \text{ V} \end{array} \right.$
Play	7.5 V $\left\{ \begin{array}{l} 2.5 \text{ V } \pm 0.4 \text{ V} \end{array} \right.$

(c) Resistors for Adjustment

Mode	Ref. No.	Typical Value
Stop	R415, R416	9.1 k Ω (F), 15 k Ω (F)
Fast (FF/REW)	R414	56 k Ω (F)
Pause	R454	680 k Ω
Play	R453	120 k Ω
Record	R419	150 k Ω

(d) Adjustment Procedures

1) Press the Stop Switch to set the N-480 in stop mode. Adjust the value of R415 and R416 to obtain 15 V (± 0.6 V) at the sliding contact of VR601.

Note: When R415 and R416 are adjusted, the reference voltage in Fast (FF or REW) mode is changed. Therefore, re-check of the reference voltage in Fast (FF or REW) mode is required. If the reference voltage is out of the range, re-adjustment of R414 according to next step 2) is necessary.

2) Set the N-480 in FF mode, then adjust the value of R414 so that the voltage of VR601 will become lower by 1.5 V (± 0.25 V) than in stop mode.

3) Press the Pause Switch to set the N-480 in pause mode.

Adjust the value of R454 to obtain 10 V ($+0.4$, -0.15 V) at the sliding contact of VR601.

4) Set the N-480 in playback mode, then adjust the value of R453 so that the voltage of VR601 will be

- come lower by 2.5 V (± 0.4 V) than in pause mode.
- 5) Short the both leads of capacitor C406 with a jumper wire.

Set the N-480 in record mode, then adjust the value of R419 so that the voltage of VR601 will become higher by 1 V ($+0.4$, -0.2 V) than in stop mode.

Note: Remove the short of C406 after completion of adjustment.

(3) Cam Timing Adjustment

- (a) Remove the wires from the Control Motor terminals to set the motor open.
- (b) Without loading a cassette tape and with pressing the record protecting switch with your finger tip, press the Record and Play Switches to set the N-480 in record mode.
- (c) Turn the Cam and bring the "PY" mark toward the pointer by hand.
Reel Motor will rotate before the "PY" mark reaches the pointer.
Adjust the value of R436 so that the voltage at the sliding contact of VR601 becomes 9.7 V (± 0.3 V) when Reel Motor starts rotation.
- (d) Observe the mute signal at the Q416 collector.
Turn the Cam referring to above step (c) and check to insure that the voltage at the sliding contact of VR601 is 9.5 V (± 0.3 V) when mute is released (mute signal changes from H to L).
(This voltage is determined by the adjustment of R436 in above step (c).)
- (e) Observe the (Play + Pause)–Position signal at the Q411 collector.
Turn the Cam referring to above step (c) and adjust the value of R432 to obtain 11.2 V (± 0.4 V) at the sliding contact of VR601 when (Play + Pause)–Position signal changes from L to H (bias oscillation will begin).
- (f) Upon completion of above adjustment, re-connect wires to the motor terminals.

5.2. Tape Speed Adjustment

- (1) Remove the Top Cover.
- (2) Connect a Frequency Counter to the Output Jack.
- (3) Load a 3 kHz Speed Wow/Flutter Tape (DA09006A) and play it back.
- (4) Referring to Fig. 5.3, adjust the Tape Speed Adjustment Volume (VR501) incorporated in the Capstan Motor to obtain 3,000 Hz on the Frequency Counter.

CCW: Motor drives slowly.

CW: Motor drives fast.

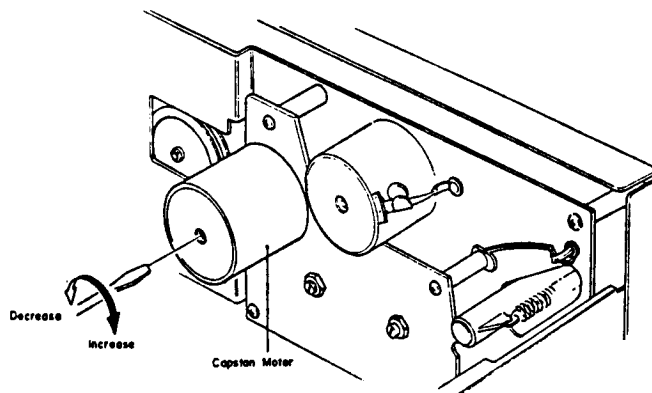

Fig. 5.3

5.3. Record/Playback Head Tilt Adjustment

On items 5.3 – 5.7, please refer to Fig. 5.4 flow chart.

Refer to Figs. 5.5 and 5.6.

- (1) Load a Tilt Check Gauge M-9036 (DA09036A) in the N-480.
- (2) Clip the grounding terminal of the Tilt Check Gauge with one end of the cord with clip, and the other end to the chassis of the N-480.
- (3) Remove Height Gear.
- (4) Set the N-480 in play mode. Check to insure whether the Beacon "Upper" or "Lower" is illuminating. In order not to give damages onto the record/playback head surface, push the slide knob of the gauge to the direction of an arrow mark, then return it to the original place to be in contact with record/playback head surface after play mode is securely locked.
- (5) Check to insure freedom from contact between the gauge and pad lifter.
- (6) Beacon "Lower" will light on when height adjustment screw turned clockwise but "Upper" when counterclockwise. Adjust so that both "Upper" and "Lower" will light on even when you move the slide knob to the direction of an arrow mark and then return it to the original place.
- (7) Set the N-480 in stop mode and fit the serrated Height Gear. Then set the N-480 again in play mode and insure 2 Beacons "Upper" and "Lower" are illuminating.
If not, (3) through (6) will have to be repeated till satisfactory results are obtained.

For Service Manuals Contact
MAURITRON TECHNICAL SERVICES
 8 Cherry Tree Rd. Chinnor
 Oxon OX9 4QY
 Tel:- 01844-351694 Fax:- 01844-352554
 Email:- enquiries@mauritron.co.uk

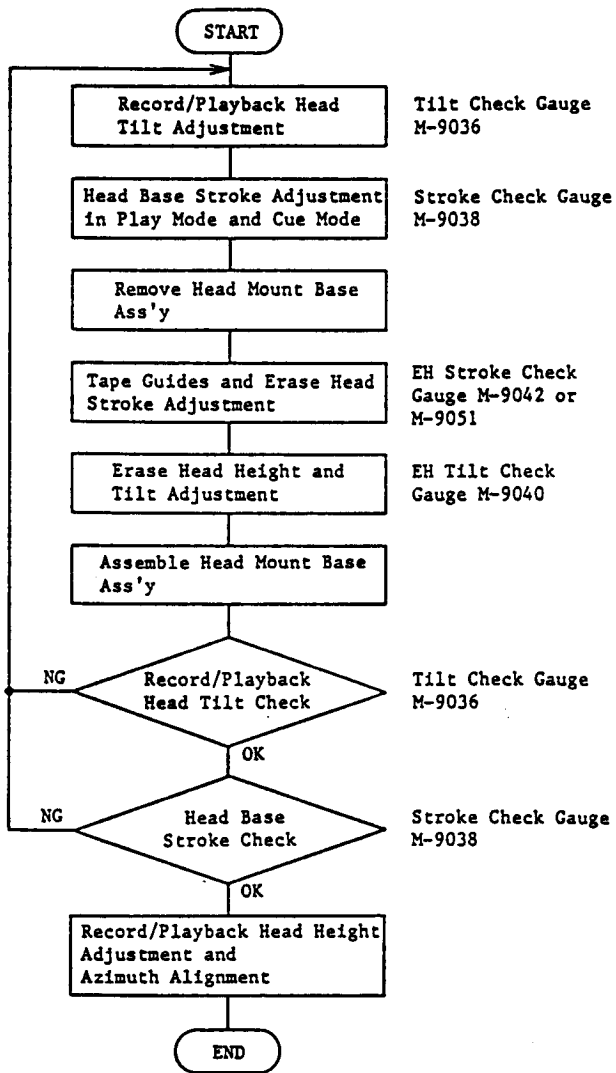

Fig. 5.4

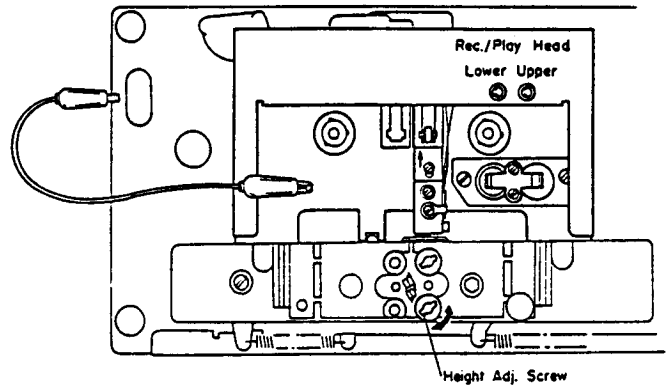

Fig. 5.5

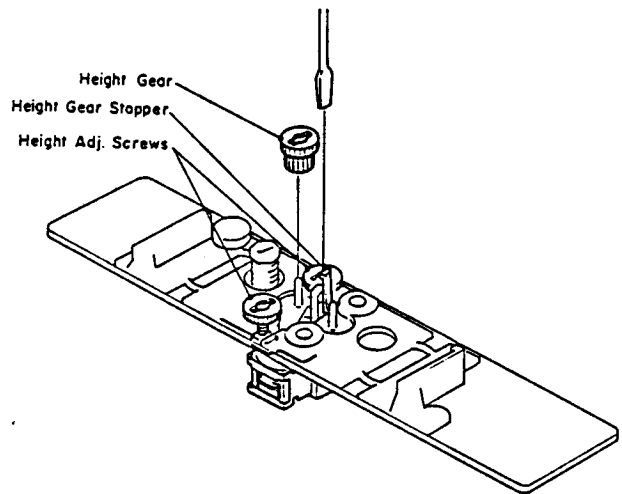

Fig. 5.6

5.4. Head Base Stroke Adjustment

Refer to Fig. 5.7.

Note: Before you conduct "Head Base Stroke Adjustment", adjust with a "Tilt Check Gauge" to insure freedom from tilt on the record/playback head.

- (1) Load a Stroke Check Gauge M-9038 (DA09038A) in the N-480.
- (2) Set the N-480 in play mode.
- (3) Check to insure whether the "P" pointer on the Stroke Indicator locates between 2 lines as marked on the Stroke Check Plate.
- (4) If the record/playback head stroke is noted to be misaligned, adjustment can be made by moving the stroke adjuster assembled in the head base assembly (either forwardly or backwardly).

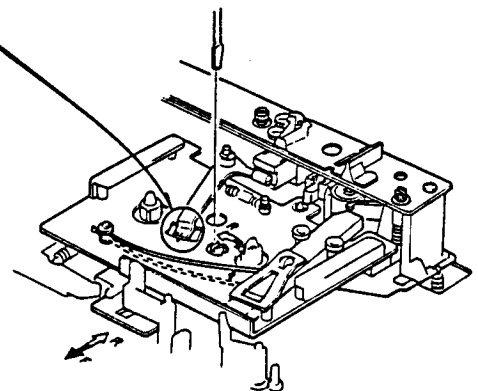
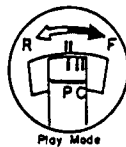

Fig. 5.7

5.5. Tape Guides Adjustment and Erase Head Stroke Adjustment

Remove Head Mount Base Ass'y. Refer to Figs. 5.8 and 5.9.

(1) Supply Tape Guide Height Adjustment

- (a) Load an EH Stroke Check Gauge M-9042/M-9051 in the N-480.
- (b) Set the N-480 in play mode.
- (c) Slide the Supply Tape Guide Check Bar down against the supply tape guide, thus check can be made on supply tape guide height.
- (d) If the supply tape guide is misaligned, the Supply Tape Guide Check Bar will not come into the supply tape guide. If such is noted, turn to adjust the height adjustment nut A till the Supply Tape Guide Check Bar is accepted by the supply tape guide.
- (e) If the above are insured, set the N-480 in pause mode, then in play mode to see whether adjustments are appropriately made. If not, (b) through (e) will have to be repeated till satisfactory results are obtained.

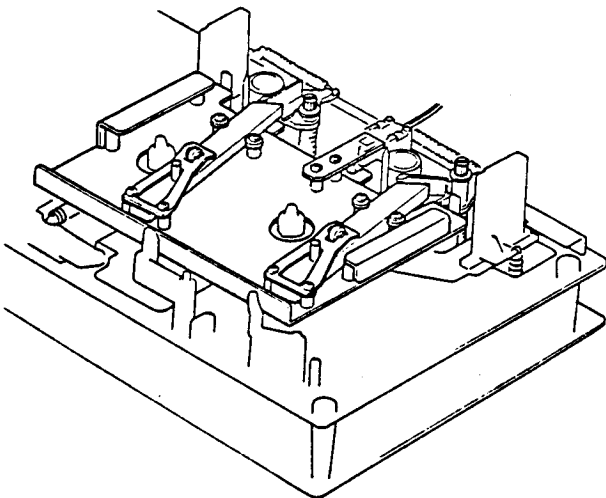

Fig. 5.8

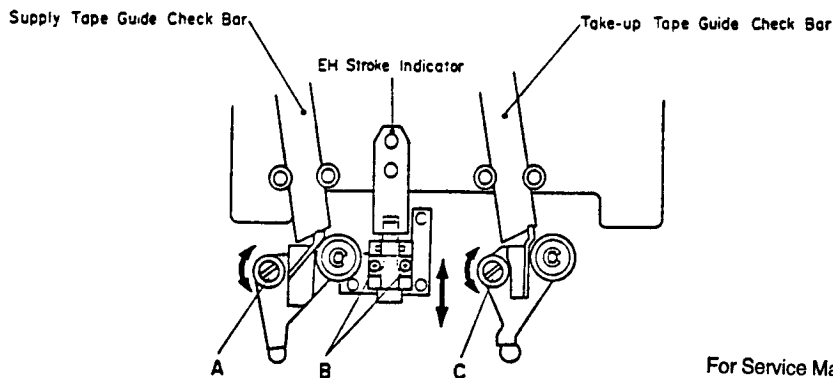

Fig. 5.9

(2) Take-up Tape Guide Height Adjustment

- (a) Load an EH Stroke Check Gauge M-9042/M-9051 in the N-480.
- (b) Set the N-480 in play mode.
- (c) Slide the Take-up Tape Guide Check Bar down against the take-up tape guide, thus check can be made on take-up tape guide height.
- (d) If the take-up tape guide is misaligned, the Take-up Tape Guide Check Bar will not come into the take-up tape guide. If such is noted, turn to adjust the height adjustment nut B till the Take-up Tape Guide Check Bar is accepted by the take-up tape guide.
- (e) If the above are insured, set the N-480 in pause mode, then in play mode to see whether adjustments are appropriately made. If not, (b) through (e) will have to be repeated till satisfactory results are obtained.

(3) Erase Head Stroke Adjustment

- (a) Load an EH Stroke Check Gauge M-9042/M-9051 in the N-480.
- (b) Set the N-480 in play mode, thus check can be made on erase head stroke through the EH Stroke Indicator.
- (c) Check to insure whether the erase head surface is aligned with red line on the EH Stroke Indicator. If not, adjust the erase head stroke by loosening 2 screws that assembled erase head and erase head plate.
- (d) After completion of adjustment, 2 pcs. of screws shall be locked with lock tight paint.

Note: EH Stroke Check Gauge M-9042 (DA09042A) should be used for the Models from Serial Nos. A304.501001 to A304.516073, and EH Stroke Check Gauge M-9051 (DA09051A) is for the Models bearing Serial Nos. A304.516074 and greater.

For Service Manuals Contact
MAURITRON TECHNICAL SERVICES
 8 Cherry Tree Rd, Chinnor
 Oxon OX9 4QY
 Tel:- 01844-351694 Fax:- 01844-352554
 Email:- enquiries@mauritron.co.uk

5.6. Erase Head Height and Tilt Adjustment

Refer to Figs. 5.10 and 5.11.

- (1) Remove Head Mount Base Ass'y.
- (2) Load an EH Tilt Check Gauge M-9040 (DA09040A) in the N-480.
- (3) Set the N-480 in stop mode.
- (4) Check to insure whether one of the 3 Beacons is illuminating. Look down the mirror as shown by an arrow mark and slowly turn the Screw "Height" counterclockwise (or clockwise) so that the two horizontal lines of the mirror will become superposed on the line (in different color) of the erase head, and check to insure whether Beacon "1" is illuminating.
- (5) Turn Screw "Tilt" counterclockwise (or clockwise) to light on Beacon "2". Excessive turning will cause the Beacon "1" to light off.

Adjustments of Screw "Tilt" will therefore be conducted till both of the Beacons "1" and "2" illuminate.

- (6) Turn Screw "Azimuth" counterclockwise (or clockwise) to light on Beacon "3". Excessive turning will cause either Beacon "1" or "2" to light off, and therefore adjust with Screw "Azimuth" until all of the 3 Beacons "1", "2" and "3" illuminate.
- (7) Check to insure whether the horizontal line on the mirror corresponds to that on the erase head. If not, (4) through (7) will have to be repeated till satisfactory results are obtained.
- (8) After completion of adjustment, 3 pcs. of screws shall be locked with lock tight paint.

Note: Before use of this gauge, check to insure freedom from dust or dirt, or overflow in the groove of the erase head surface.

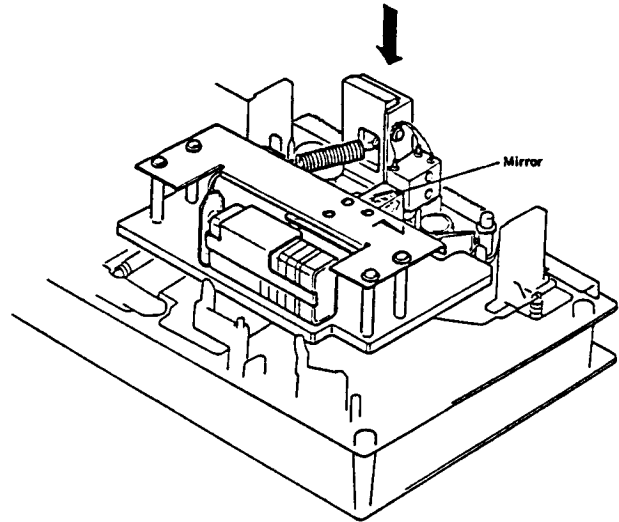

Fig. 5.10

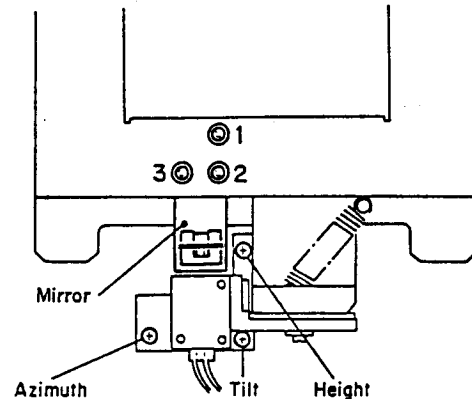

Fig. 5.11

5.7. Record/Playback Head Height Adjustment and Azimuth Alignment

Refer to Fig. 5.12.

- (1) Connect a VTVM to the Output Jacks.
- (2) Load a 1 kHz Track Alignment Tape (DA09007A) in the N-480.
- (3) Set the N-480 in play mode.
- (4) Turn the Height Gear until the output of both channels becomes minimum.
- (5) Load a 15 kHz Azimuth Tape (DA09004A) in the N-480.
- (6) Set the N-480 in play mode.
- (7) Turn the Azimuth Alignment Screw until the output of both channels becomes maximum.
- (8) Repeat (2) through (7) 1 - 2 times.

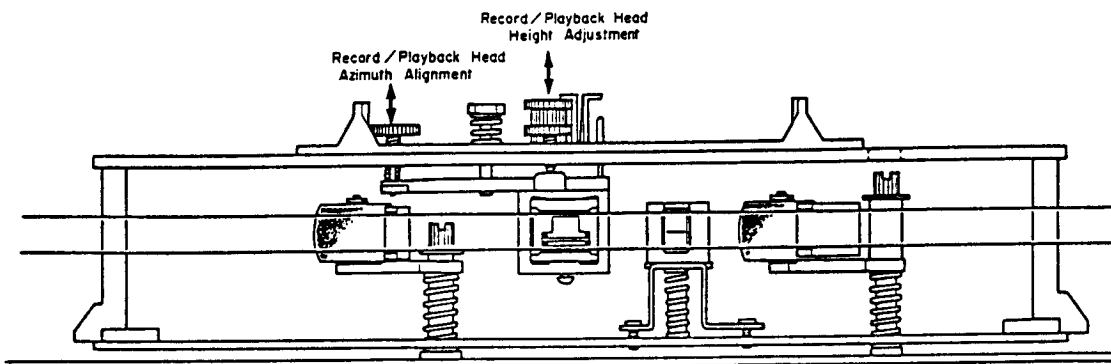

Fig. 5.12

5.8. Tape Travelling Adjustment

The adjustment shall be made with a modified version of the current type EXII C-90 tape as shown in the Fig. 5.13 (error will be made if a current type Tape Travelling Cassette (DA09011A) should be used for this purpose). While modifying an EXII C-90 tape, the tape guides in the cassette housing shall be kept protected to avoid tilt.

Check shall be made in the following procedures:

- (1) An EXII C-90 tape thus modified shall be loaded onto the N-480.
- (2) Release the back-tension (rotate the supply reel and feed out some length of tape) and set the N-480 in play mode.
- (3) In this juncture, check to insure whether the tape is freedom from waving or slippage from the both of tape guides.
- (4) When the modified EXII C-90 tape is played back, check to insure whether the tape is freedom from waving from head surface or at pressure rollers.
- (5) If either of waving or slippage from the tape guides should be noted, adjustments of "5.3. Record/Playback Head Tilt Adjustment", "5.4. Head Base Stroke Adjustment", "5.5. Tape Guides Adjustment and Erase Head Stroke Adjustment", "5.6. Erase Head Height and Tilt Adjustment", "5.7. Record/Playback Head Height Adjustment and Azimuth Alignment", etc. will be required.

As a case may be, the said waving or slippage may have been caused from defective Supply Pressure Roller Ass'y or Take-up Pressure Roller Ass'y without parallel contact with Capstans.

If such are noted, the Pressure Roller Assemblies will have to be replaced. Further, excessively weak take-up torque or strong take-up torque may cause defective tape travelling.

The N-480 is intended to be adjustment-free Model. However if the similar matters as above should be noted, please replace the Reel Hub Take-up Ass'y to obtain appropriate take-up torque.

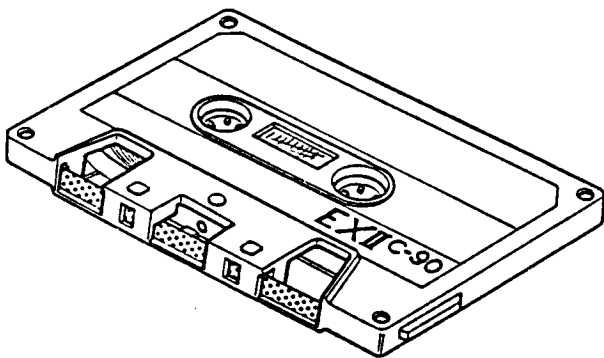

Fig. 5.13

5.9. Record Switch Linkage Adjustment

- (1) Set the N-480 in stop mode.
- (2) Loosen the screw of the Record Spring Holder, and shift the Record Spring Holder in order to remove the looseness of the Linkage Wire as shown in Fig. 5.14.1. Then tighten the screws for fixing the Record Spring Holder. (In this case, the Record Switch should be positioned at play side. If on the record position, it will be defective.)
- (3) Set the N-480 in record and pause mode. Check to insure that the gap between the top of the wire and the Record Spring Holder is approx. 1 mm as shown in Fig. 5.14.2. (Check that the Record Switch is in record position.)
- (4) Upon completion of the above adjustments, apply a quantity of lock tight paint.

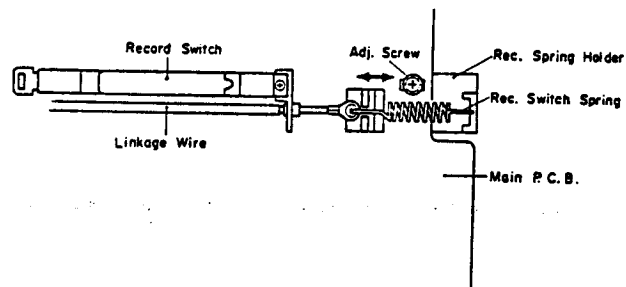

Fig. 5.14.1

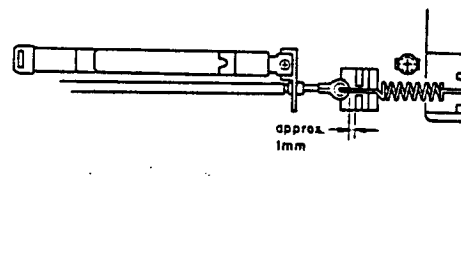

Fig. 5.14.2

For Service Manuals Contact
MAURITRON TECHNICAL SERVICES
 8 Cherry Tree Rd, Chinnor
 Oxon OX9 4QY
 Tel: 01844-351694 Fax: 01844-352554
 Email: enquiries@mauriton.co.uk

5.10. Flywheel Holder Adjustment

(1) Refer to Fig. 5.15.

Tighten the Thrust Screws until the gap between the Flywheel Assemblies and Thrust Screws becomes minimized when both of the Capstan Shafts are moved backwardly and forwardly (the Thrust Springs between the Capstan Flanges and Flywheel Thrust Caps are in a flat state).

Excessive tightening of the Thrust Screws however will give damages on the Flywheel Assemblies, to which careful attention is invited.

- (2) Return the Thrust Screws by 1/2 turn.
- (3) Fixing the Thrust Screws with a screwdriver, lock the Lock Nut.
- (4) Apply a quantity of lock tight paint to the Thrust Screws.

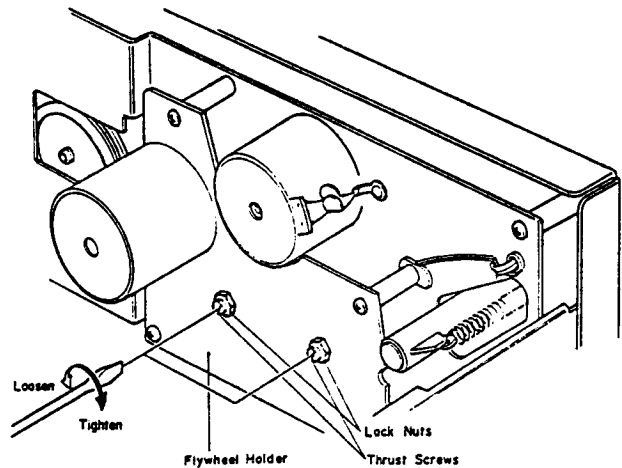

Fig. 5.15

5.11. Eject Wire Adjustment

- (1) Referring to Fig. 5.16.1, insert a 1.5 mm spacer between the Eject Arm and Eject Stopper by turning the Eject Arm in the illustrated direction, then set the N-480 in playback mode.
- (2) With pushing the Eject Arm by hand, loosen the screw and then pull the Eject Wire in the direction of the arrow until it stops as shown in Fig. 5.16.2.
- (3) Tighten the screw, then apply a quantity of lock tight paint.

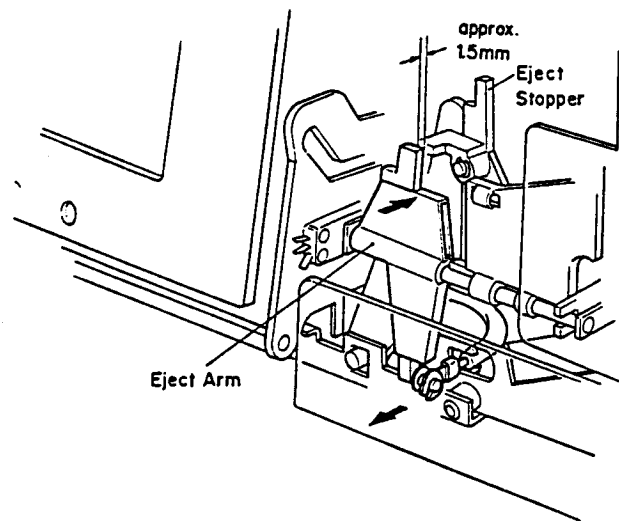

Fig. 5.16.1

5.12. Lubrication

N-480 is a lubrication-free cassette deck except when parts are replaced. Apply the following lubricant for each replaced part:

- (1) LAUNA #100
Capstan Shaft
Pressure Roller Shaft
Thrust Cap
- (2) FLOIL GB-TS-1
Reel Hub Shaft
Thrust portion on the Capstan Shaft
FLOIL GB-TS-1, made by Kanto Chemicals Co., Ltd., in Japan.
We suggest you use the above or equivalent type. If unavailable please contact Kanto Chemicals Co., Ltd., 2-7 Kanda Suda-cho Chiyoda-ku, Tokyo 101 Japan.
- (3) Silicon Oil #3000 CST
Air Damper Piston

Note: Excessive lubrication may cause defective damper action as the 0.2φ hole at the end of the cylinder may be filled with oil.

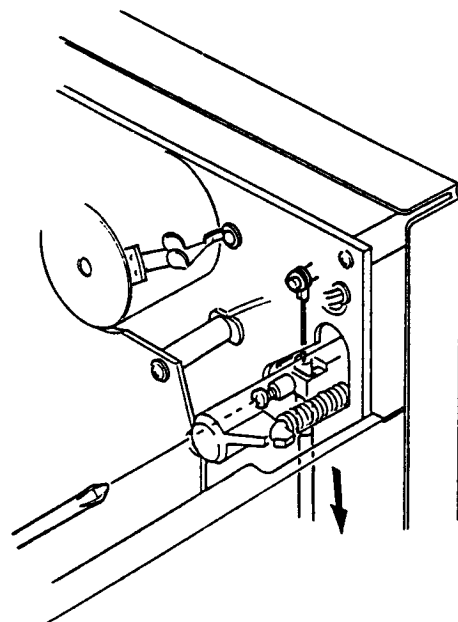
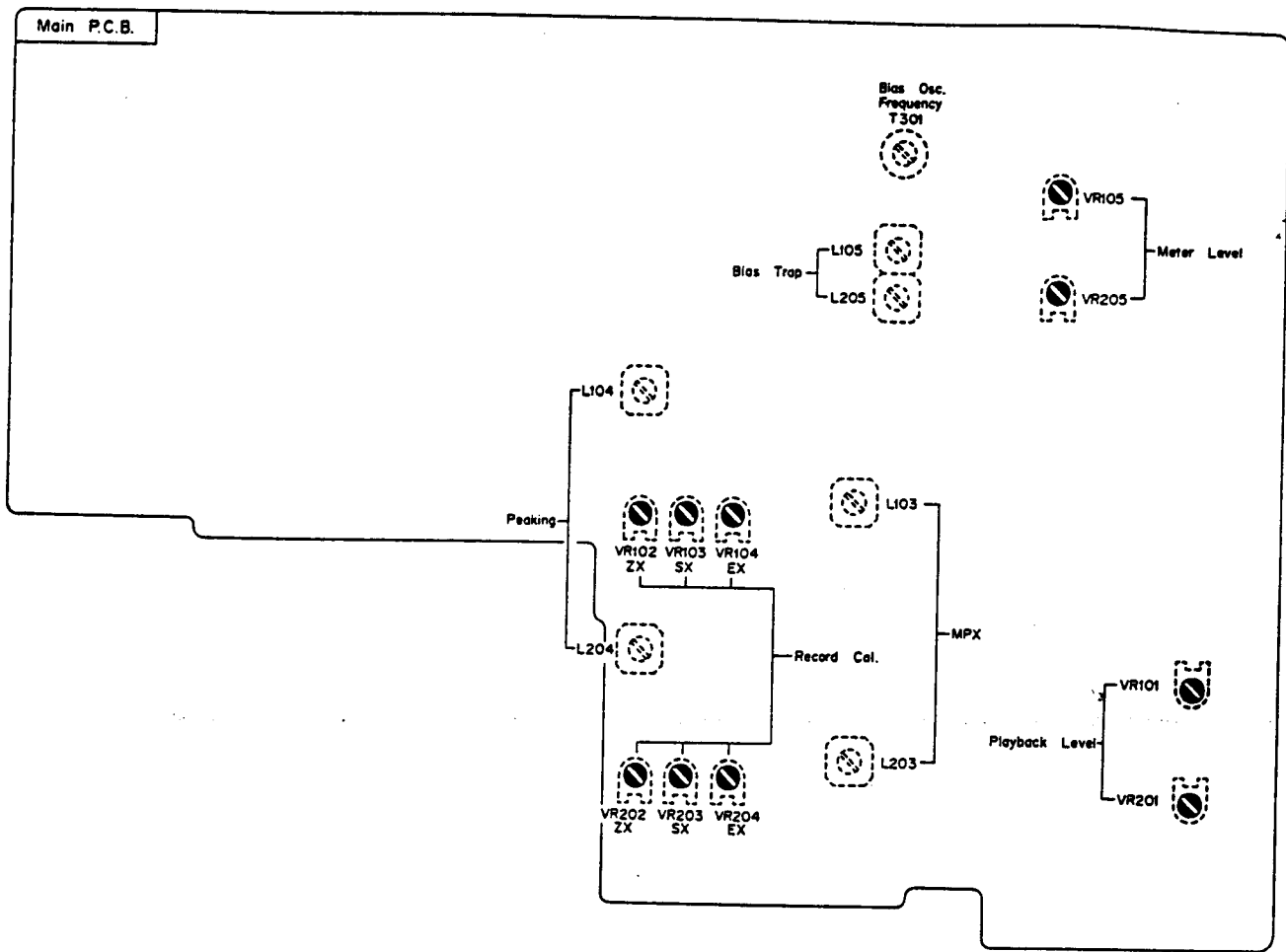

Fig. 5.16.2

6. PARTS LOCATION FOR ELECTRICAL ADJUSTMENT



For Service Manuals Contact
MAURITRON TECHNICAL SERVICES
 8 Cherry Tree Rd, Chinnor
 Oxon OX9 4QY
 Tel:- 01844-351694 Fax:- 01844-352554
 Email:- enquiries@mauritron.co.uk

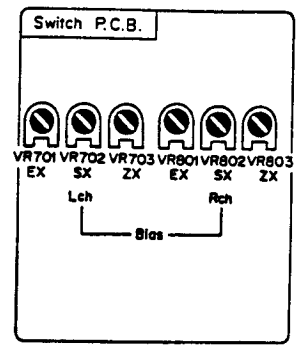
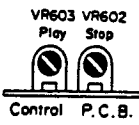

Fig. 6

7. ELECTRICAL ADJUSTMENTS AND MEASUREMENTS

7.1. Adjustment and Measurement Instructions

Note: Electrical adjustment should be performed after mechanical adjustment is completed.

STEP	ITEM	SIGNAL SOURCE	OUTPUT CONNECTION	MODE	ADJUSTMENT	REMARKS
1	Tape Speed	3 kHz Speed and Wow/Flutter Tape (DA09006A)	Frequency Counter to OUTPUT Jacks	Playback Eq. SW - 70 μs	Capstan Motor Governor P.C.B. VR501	Adjust VR501 to obtain 3 kHz ± 0.5%. (VR501 is incorporated in the capstan motor.)
2	Meter Level	400 Hz to INPUT Jacks	VTVM to TP101, TP201 on the Main P.C.B.	Record, Pause	Main P.C.B. VR105, VR205	1. Set the input level controls to maximum. 2. Adjust the oscillator output to obtain 100 mV at TP101 (TP201), then adjust VR105 (VR205) to obtain 0 dB on the level meters.
3	MPX Filter	19 kHz ± 100 Hz to INPUT Jacks	VTVM to OUTPUT Jacks	Record, Pause MPX SW - OUT/IN	Main P.C.B. L103, L203	1. Adjust input level controls to obtain 600 mV on the VTVM. 2. Set the MPX Switch to IN position, then adjust L103 (L203) to obtain minimum reading on the VTVM (minimum reading will be less than -30 dB).
4	Record/Playback Head Track Alignment	1 kHz Track Alignment Tape (DA09007A)	Same as above	Playback MPX SW - OUT Eq. SW - 70 μs Dolby NR SW - OUT	Record/Playback Head Height Adjustment Screw	Adjust the Record/Playback Head Height Adj. Screw to obtain minimum reading of both L and R channels on the VTVM. See "Record/Playback Head Height Adjustment and Azimuth Alignment" in item 5.7.
5	Record/Playback Head Azimuth Alignment	15 kHz Azimuth Tape (DA09004A)	Same as above	Same as above	Record/Playback Head Azimuth Alignment Screw	Adjust the Record/Playback Head Azimuth Alignment Screw to obtain maximum reading of both L and R channels on the VTVM. See "Record/Playback Head Height Adjustment and Azimuth Alignment" in item 5.7. Note: Repeat steps 4 and 5 one or two times to obtain optimum performance.
6	Playback Level	400 Hz Level Tape (DA09005A)	VTVM to TP101, TP201	Same as above	Main P.C.B. VR101, VR201	Adjust VR101 (VR201) to obtain 100 mV on the VTVM or 0 dB on the level meters.
7	Playback Frequency Response	400 Hz Level Tape (DA09005A) 10 kHz PB Frequency Tape (DA09003A) 15 kHz PB Frequency Tape (DA09002A) 20 kHz PB Frequency Tape (DA09001A)	VTVM to OUTPUT Jacks	Same as above	Main P.C.B. R112, R212	1. Load the 400 Hz level tape and play it back. 2. Load the 10 kHz, 15 kHz and 20 kHz PB Frequency Response Tapes and adjust the record/playback head azimuth to give maximum levels on the VTVM with each tape. Short R112 (R212) to obtain the following levels against 400 Hz level tape. Refer to Fig. 7.3. 10 kHz (-20 dB) -2 dB to +2 dB 15 kHz (-20 dB) -2 dB to +3 dB 20 kHz (-20 dB) -2 dB to +4 dB 3. Conduct step 5 "Record/Playback Head Azimuth Alignment" 4. If above is not sufficient, refer to "Playback Frequency Response Adjustment" in item 7.2.

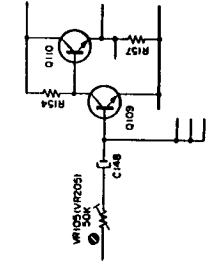

Fig. 7.1
2. Meter Level

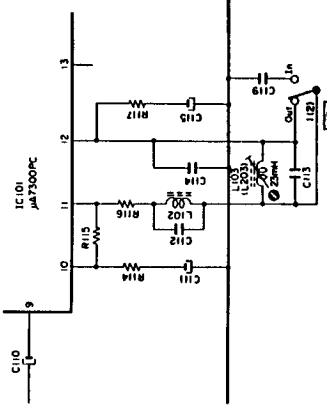

Fig. 7.2
3. MPX Filter

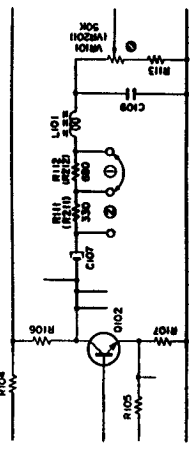

Fig. 7.3
6. Playback Level
7. Playback Frequency Response

STEP	ITEM	SIGNAL SOURCE	OUTPUT CONNECTION	MODE	ADJUSTMENT	REMARKS
8	Bias Oscillation Frequency and Erase Current	External 0.1 Ω Resistor in series to Erase Head	VTVM and Frequency Counter across the 0.1 Ω Resistor	Record, Pause ZX SW - IN Eq. SW - 70 μ s Dolby NR SW - OUT MPX SW - OUT	Main P.C.B. T301 R310, R311	<ol style="list-style-type: none"> Adjust T301 to obtain 105 kHz on the frequency counter. Check the erase current by the VTVM. Erase current will be in a range of 310 mA to 400 mA (typically approx. 350 mA). If erase current is not sufficient, increase it by shorting R310 or R311. After completion of the erase current adjustment, re-check the bias oscillation frequency.
9	Record Amplifier Equalizer	21 kHz (-20 dB) to INPUT Jacks	VTVM to TP102, TP202	Same as above	Main P.C.B. L104, L204	<ol style="list-style-type: none"> Remove the bias-cut-jumper from the dip side of the Main P.C.B. Adjust L104 (L204) to obtain peak reading at 21 kHz on the VTVM. Re-solder the bias-cut-jumper.
10	Bias Trap	Remove INPUT Signals	Same as above	Same as above	Main P.C.B. L105, L205	<ol style="list-style-type: none"> Set the input level controls to obtain 0 dB on the level meters. Record signals on the reference EX11 (DA09021A), reference SX (DA09025A) or reference ZX (DA09037A), then play it back. Repeating 2 as above, adjust VR104 (VR204) (for EX11), VR103 (VR203) (for SX) and VR102 (VR202) (for ZX) to obtain 0 dB on the level meters in playback mode.
11	Record Level Calibration	400 Hz to INPUT Jacks	VTVM to OUTPUT Jacks	Record and Playback ZX SW - IN/OUT SX/EX SW - SX/EX Eq. SW - 120 μ s (EX) 70 μ s (SX/ZX) Dolby NR SW - OUT MPX SW - OUT	Main P.C.B. VR102, VR202 VR103, VR203 VR104, VR204	<ol style="list-style-type: none"> Set the input level controls to obtain 0 dB on the level meters. Record signals on the reference EX11 (DA09021A), reference SX (DA09025A), or reference ZX (DA09037A). Repeating 2 as above, play back the tape and adjust VR701 (VR801) (for EX11), VR702 (VR802) (for SX) or VR703 (VR803) (for ZX) to obtain maximum reading on the VTVM. Conduct step 11 "Record Level Calibration". Feed in 10 kHz (-20 dB) then record and play it back. Adjust VR104 (VR204) (for EX11), VR103 (VR203) (for SX) or VR102 (VR202) (for ZX) on the Main P.C.B. As'y to obtain approximately -20 dB on the VTVM. Feed in 18 kHz (-20 dB) then record and play it back. Adjust recording peaking coil L104 (L204) to obtain approximately -20 dB on the VTVM (refer to step 9 "Record Amplifier Equalizer"). Conduct step 11 "Record Level Calibration". Feed in 400 Hz and adjust the input level controls to obtain 0 dB on the level meters, then record and play it back and check to insure whether the Total Harmonic Distortion (T.H.D.) is less than 1.0% for EX11, 1.2% for SX and 1.0% for ZX. Feed in 20 Hz to 18 kHz (-20 dB) then record and play it back, and check to insure whether the output levels are within -20 dB \pm 4 dB. If T.H.D. exceeds 1.2%, the following adjustments are required: <ol style="list-style-type: none"> Repeat 5 as above. Adjust bias calibration semi-fixed volumes and peaking coils to obtain -22 dB instead of -20 dB on the VTVM. Perform step 11 "Record Level Calibration". Repeat 7 as above. If above is not sufficient, precise re-adjustment of step 7 "Playback Frequency Response", replacement of Record/Playback Head or check of item 5.8 "Tape Travelling Adjustment" will be required.
12	Recording Bias Current and Overall Frequency Response	400 Hz to INPUT Jacks and 20 Hz to 18 kHz (-20 dB) to INPUT Jacks	VTVM and Distortion Meter to OUTPUT Jacks	Record and Playback ZX SW - IN/OUT SX/EX SW - SX/EX Eq. SW - 120 μ s (EX) 70 μ s (SX/ZX) Dolby NR SW - OUT MPX SW - OUT	Switch P.C.B. VR701, VR801 VR702, VR802 VR703, VR803	<ol style="list-style-type: none"> Feed in 400 Hz and adjust input level controls to obtain 0 dB on the level meters. Record signals on the reference EX11 (DA09021A), reference SX (DA09025A), or reference ZX (DA09037A). Repeating 2 as above, play back the tape and adjust VR701 (VR801) (for EX11), VR702 (VR802) (for SX) or VR703 (VR803) (for ZX) to obtain maximum reading on the VTVM. Conduct step 11 "Record Level Calibration". Feed in 10 kHz (-20 dB) then record and play it back. Adjust VR104 (VR204) (for EX11), VR103 (VR203) (for SX) or VR102 (VR202) (for ZX) on the Main P.C.B. As'y to obtain approximately -20 dB on the VTVM. Feed in 18 kHz (-20 dB) then record and play it back. Adjust recording peaking coil L104 (L204) to obtain approximately -20 dB on the VTVM (refer to step 9 "Record Amplifier Equalizer"). Conduct step 11 "Record Level Calibration". Feed in 400 Hz and adjust the input level controls to obtain 0 dB on the level meters, then record and play it back and check to insure whether the Total Harmonic Distortion (T.H.D.) is less than 1.0% for EX11, 1.2% for SX and 1.0% for ZX. Feed in 20 Hz to 18 kHz (-20 dB) then record and play it back, and check to insure whether the output levels are within -20 dB \pm 4 dB. If T.H.D. exceeds 1.2%, the following adjustments are required: <ol style="list-style-type: none"> Repeat 5 as above. Adjust bias calibration semi-fixed volumes and peaking coils to obtain -22 dB instead of -20 dB on the VTVM. Perform step 11 "Record Level Calibration". Repeat 7 as above. If above is not sufficient, precise re-adjustment of step 7 "Playback Frequency Response", replacement of Record/Playback Head or check of item 5.8 "Tape Travelling Adjustment" will be required. Conduct step 11 "Record Level Calibration".

For Service Manuals Contact
MAURITRON TECHNICAL SERVICES
 8 Cherry Tree Rd, Chinnor
 Oxon OX9 4QY
 Tel:- 01844-351694 Fax:- 01844-352554
 Email:- enquiries@mauritron.co.uk

STEP	ITEM	SIGNAL SOURCE	OUTPUT CONNECTION	MODE	ADJUSTMENT	REMARKS
13	Crosstalk	1 kHz to INPUT Jacks	1 kHz Band Pass Filter and VTVM to OUTPUT Jacks	Record and Playback ZX SW - OUT SX/EX SW - SX Eq. SW - 70 μs Dolby NR SW - OUT MPX SW - IN		1. Erase the tape with bulk eraser. 2. Adjust the input level controls to obtain 0 dB on the level meters, and record the signals on the reference SX tape (DA09025A). 3. Turn the cassette tape the other way round and play it back. 4. Measure the difference between 2 and 3.
14	Channel Separation	1 kHz to INPUT Jacks	Same as above	Same as above		1. Erase the tape with bulk eraser. 2. Adjust L ch (R ch) input level control to obtain 0 dB on the level meter, and close R ch (L ch) input level control. 3. Record and play it back, then measure the R ch (L ch) level.
15	Erase	100 Hz to INPUT Jacks	100 Hz Band Pass Filter and VTVM to OUTPUT Jacks	Record and Playback ZX SW - IN Eq. SW - 70 μs Dolby NR SW - OUT MPX SW - IN		1. Erase the tape with bulk eraser. 2. Adjust input level controls to obtain 0 dB on the level meters, and record the signals on the reference ZX tape (DA09037A). 3. Rewind the tape, close input level controls, and then record again. 4. Rewind the tape, play it back, and then measure the difference between 2 and 3.
16	Signal to Noise Ratio	400 Hz to INPUT Jacks	IHF-A Curve Filter, Distortion Meter and VTVM to OUTPUT Jacks	Record and Playback ZX SW - IN Eq. SW - 70 μs Dolby NR SW - IN MPX SW - IN		1. Feed in 400 Hz and record, and play it back. 2. Adjust the input level controls to obtain 3% total harmonic distortion in playback mode. 3. Close the input level controls then record. 4. After re-reading, play back and check the output level difference between 2 and 3. Note: The filter of IHF-A curve shall be used in the measurements.
17	Total Harmonic Distortion	400 Hz to Input Jacks	Distortion Meter to OUTPUT Jacks	Record and Playback ZX SW - IN/OUT SX/EX SW - SX/EX Eq. SW - 120 μs (EX) 70 μs (SX, ZX) Dolby NR SW - OUT MPX SW - IN		1. Adjust the input level controls to obtain 0 dB on the level meters. 2. Record and play it back. 3. Read the distortion meter and check to insure that the distortion is as follows: EX II 1.0% or less SX 1.2% or less ZX 1.0% or less
18	Wow/Flutter	3 kHz Speed and Wow/Flutter Tape (DA09006A)	Wow/Flutter Meter to OUTPUT Jacks	Playback Eq. SW - 70 μs		Playback and read the wow/flutter meter.

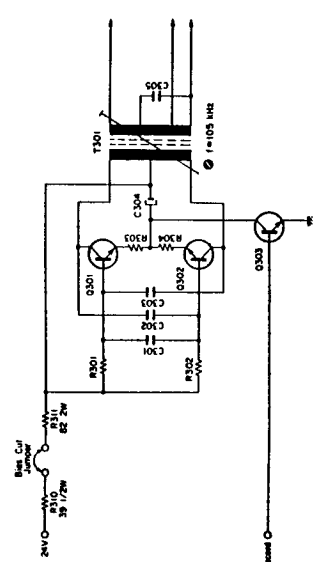

Fig. 7.4 8. Bias Oscillation Frequency and Erase Current

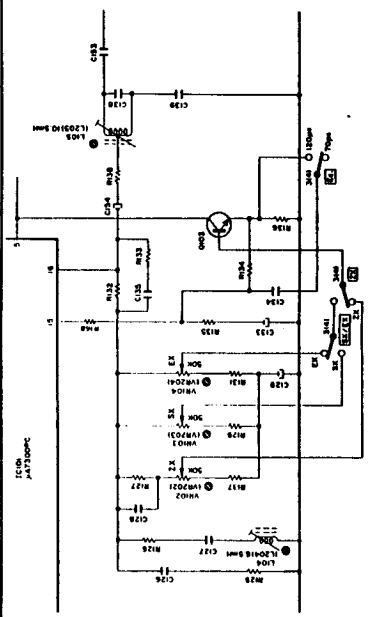
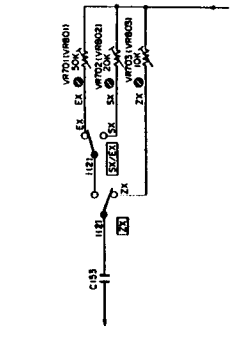

Fig. 7.5 9. Record Amplifier Equalizer
10. Bias Trap
11. Record Level Calibration



8. MOUNTING DIAGRAMS AND PARTS LIST

Note: Mounting diagram shows a dip side view of the printed circuit board.

8.1. Volume P.C.B. Assy



Fig. 8.1

8.2. Control Switch P.C.B. Assy

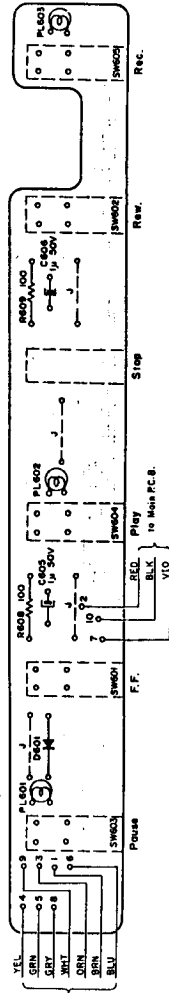

Fig. 8.2

Note: Diode is 1SS53 unless otherwise specified.

8.3. Switch P.C.B. Assy

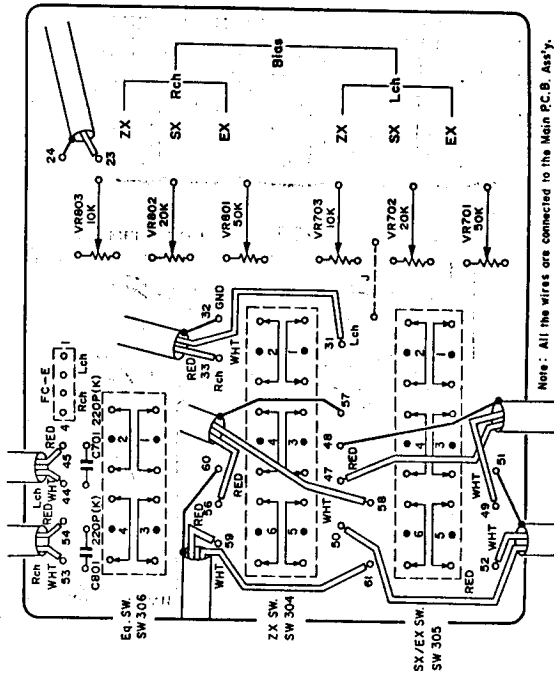

Fig. 8.3

Note: All the wires are connected to the Main P.C.B. Assy.

8.4. Control P.C.B. Assy

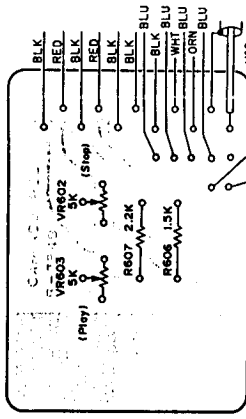

Fig. 8.4

8.5. Auto Shut-off P.C.B. Assy

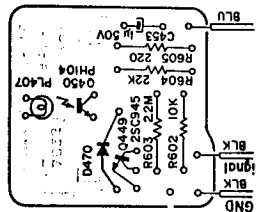

Fig. 8.5

Note: Diode is 1SS53 unless otherwise specified.

8.6. Lamp P.C.B. L Assy

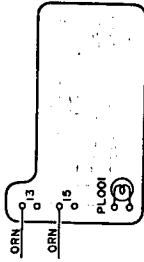

Fig. 8.6

8.7. Lamp P.C.B. R Assy

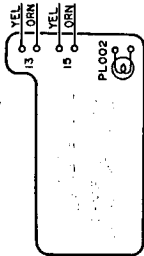

Fig. 8.7

Schematic Ref. No.	Part No.	Description	Schematic Ref. No.	Part No.	Description
VR001,002	BA04114A	Volume P.C.B.		BA04128A	Auto Shut-off P.C.B. Assy
	0807845B	Volume P.C.B.	Q449	0807852B	Auto Shut-off P.C.B.
	0807298A	Slide Volume	Q450	0806100A	Transistor 2SC945 (A)
	BA04126A	Control P.C.B. Assy	D470	0806228A	Photo Transistor PH104
VR602,603	0807849B	Control P.C.B.	R602	0806181A	Silicon Diode 1SS53
R606	0809059A	Semi-fixed Volume 5K	R603	0801888A	Carbon Resistor 10K ERD-25T J
R607	0806598A	Carbon Resistor 1.5K ERD-25T J	R604	0805671A	Carbon Resistor 2.2M ERD-25T J
	0805622A	Carbon Resistor 2.2K ERD-25T J	R605	0805615A	Carbon Resistor 22K ERD-25T J
	BA04127A	Switch P.C.B. Assy	C453	0801933A	Carbon Resistor 220 ERD-25T J
VR701,801	0807846C	Switch P.C.B.	PL407	0801405A	Electrolytic Capacitor 1μ 50V
VR702,802	0807237A	Semi-fixed Volume 50K		0808552A	Lamp 12V 25mA
VR703,803	0807261A	Semi-fixed Volume 20K	PL001	BA04125A	Lamp P.C.B. L Assy
C701, 801	0807236A	Semi-fixed Volume 10K		0807851B	Lamp P.C.B. L
	0809283A	Ceramic Capacitor 220P 50V K		0808674A	Lamp
	0807302A	Push Switch 6-6-4		BA04124A	Lamp P.C.B. R Assy
	BA04113A	Control Switch P.C.B. Assy	PL002	0807850B	Lamp P.C.B. R
D601	0807848B	Control Switch P.C.B.		0808674A	Lamp
R608, 609	0806181A	Silicon Diode 1SS53			
C605, 606	0801679A	Carbon Resistor 100 ERD-25T J			
PL601, 602	0801405A	Electrolytic Capacitor 1μ 50V			
603	0808673A	Lamp 24V 20mA			
	0807297A	Control Switch			
		(1 pce.)			

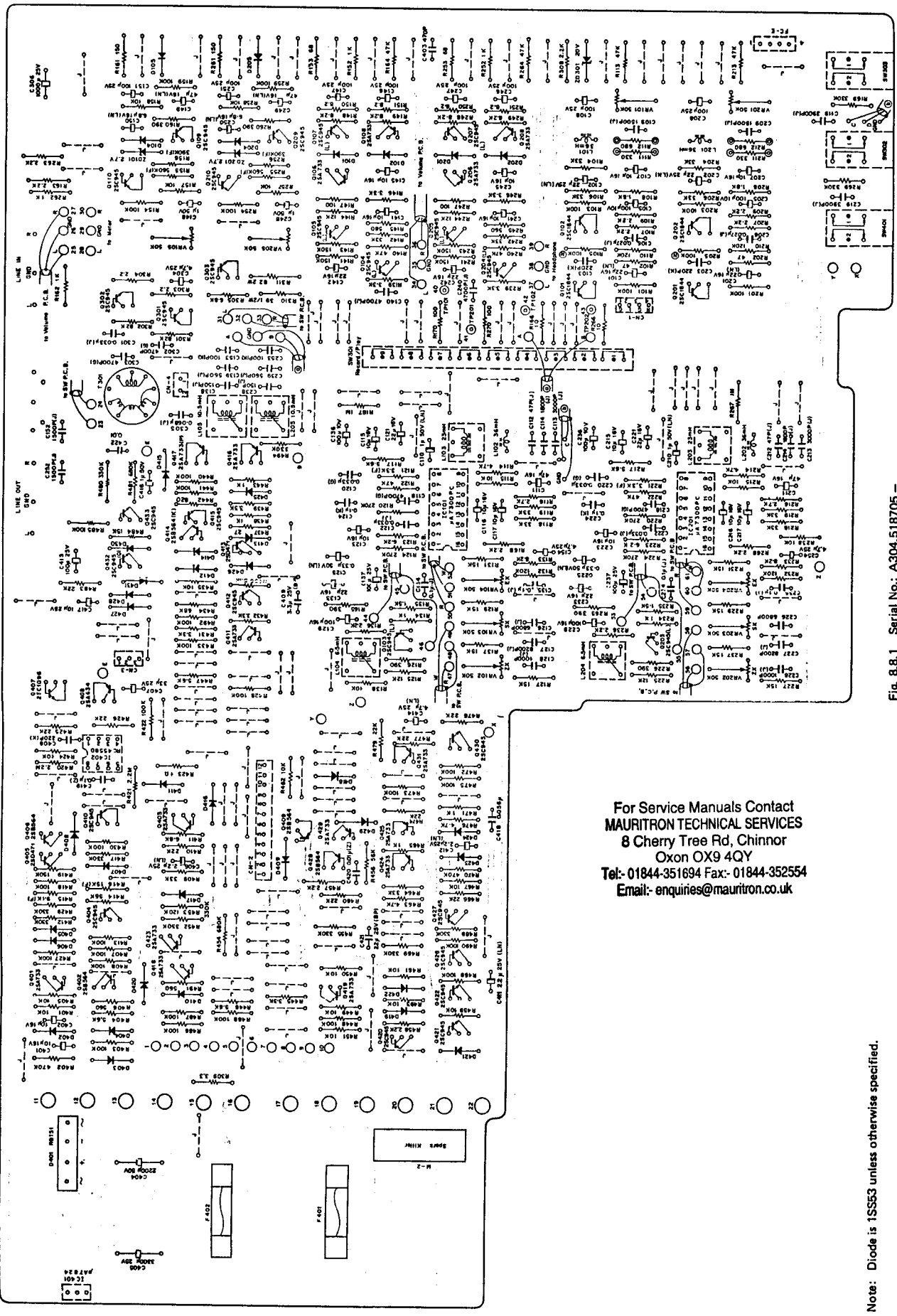

Fig. 8.8.1 Serial No.: A304.518705 -

For Service Manuals Contact
MAURITRON TECHNICAL SERVICES
 8 Cherry Tree Rd, Chinnor
 Oxon OX9 4QY
 Tel:- 01844-351694 Fax:- 01844-352554
 Email:- enquiries@mauritron.co.uk

Note: Diode is 1SS53 unless otherwise specified.

Part No.	Description	Schematic Ref. No.	Part No.	Description	Schematic Ref. No.	Part No.	
OB01913A	Mylar Capacitor 1800P 50V J	R144, 244	OB09263A	Carbon Resistor 12K ERD-25T J	Q425, 429		
OB01412A	Electrolytic Capacitor 10μ 16V	R145, 245	OB05575A	Carbon Resistor 560 ERD-25T J	431	OB06069A	Transistor
		R147, 247	OB01679A	Carbon Resistor 100 ERD-25T J	Q402, 406		
		R148, 149	OB01856A	Carbon Resistor 8.2K ERD-25T J	409, 428	OB06100A	Transistor
		248, 249			Q404, 410		
OB09191A	PP Capacitor 4700P 100V G	R150, 151	OB09331A	Fail Safe Type Resistor 8.2 RDF-25S J	412, 415		
OB01804A	Mylar Capacitor 3900P 50V J	250, 251			420, 421		
OB09240A	PP Capacitor 0.033μ 100V G	R152, 252	OB01857A	Carbon Resistor 1K ERD-25T J	422, 426		
OB01862A	Electrolytic Capacitor 22μ 16V	R153, 253	OB09306A	Fail Safe Type Resistor 68 RDF-25S J	427, 430		
OB05583A	Mylar Capacitor 0.033μ 50V J	R163, 263	OB05622A	Carbon Resistor 2.2K ERD-25T J	433		
OB01603A	Mylar Capacitor 0.1μ 50V K	R164, 264	OB05641A	Carbon Resistor 47K ERD-25T J	Q405, 413	OB06066A	Transistor
OB09327A	Electrolytic Capacitor 0.33μ 50V (LN)	R170, 270	OB01679A	Carbon Resistor 100 ERD-25T J	Q407	OB06020A	Transistor
OB05885A	Electrolytic Capacitor 100μ 10V	C140, 240	OB05652A	Mylar Capacitor 4700P 50V J	Q408	OB06012A	Transistor
OB01272A	Electrolytic Capacitor 100μ 25V	C141, 145	OB01412A	Electrolytic Capacitor 10μ 16V	Q414	OB06252A	Transistor
		241, 245			Q417	OB06155A	Transistor
- Rec. Amp. -		C142, 242	OB01862A	Electrolytic Capacitor 22μ 16V	Q432	OB06251A	Transistor
		C146, 147	OB01272A	Electrolytic Capacitor 100μ 25V	D403-431	OB06181A	Silicon Dic
OB01872A	Transistor 2SC945 (L)	246, 247			R403, 407	OB01889A	Carbon Re
OB00068A	Trap Coil 10.5mH	C152, 252	OB05653A	Mylar Capacitor 1500P 50V J	408, 413		
					418, 422		
OB07237A	Semi-fixed Volume 50K		- Meter Amp. -		427, 428		
					430, 433		
OB01683A	Carbon Resistor 15K ERD-25T J	Q109, 110	OB06100A	Transistor 2SC945 (A)	440, 441		
		209, 210			448, 468		
		ZD101,201	OB06191A	Zener Diode 2.7EB	472, 473		
		D104, 105	OB06181A	Silicon Diode 1SS53	475, 485		
		204, 205			486, 487		
OB09263A	Carbon Resistor 12K ERD-25T J	VR105,205	OB07237A	Semi-fixed Volume 50K	488, 490		
OB05691A	Carbon Resistor 390 ERD-25T J	R154, 159	OB01889A	Carbon Resistor 100K ERD-25T J	492		
OB05621A	Carbon Resistor 120K ERD-25T J	254, 259			R404, 446	OB01887A	Carbon Re
OB01856A	Carbon Resistor 8.2K ERD-25T J	R155, 255	OB09318A	Metal Film Resistor 560K SN14K2E F	447		
OB01857A	Carbon Resistor 1K ERD-25T J	R156, 256	OB09338A	Metal Film Resistor 390K SN14K2E F	R405, 424	OB01888A	Carbon Re
OB05698A	Carbon Resistor 1.5K ERD-25T J	R157, 158	OB01888A	Carbon Resistor 10K ERD-25T J	435, 449		
OB05622A	Carbon Resistor 2.2K ERD-25T J	257, 258			450, 451		
		R160, 260	OB05691A	Carbon Resistor 390 ERD-25T J	459, 461		
OB01888A	Carbon Resistor 10K ERD-25T J	R161, 261	OB09213A	Fail Safe Type Resistor 150 RDF-25S J	462, 467		
OB05530A	Mylar Capacitor 6800P 50V J	C148, 248	OB01405A	Electrolytic Capacitor 1μ 50V	493		
OB05814A	Mylar Capacitor 8200P 50V J	C149, 249	OB09218A	Electrolytic Capacitor 47μ 16V (LN)	R406, 491	OB05575A	Carbon Re
OB05550A	Mylar Capacitor 1000P 50V J	C150, 250	OB09219A	Electrolytic Capacitor 6.8μ 16V (LN)	R409, 464	OB05509A	Carbon Re
OB01400A	Electrolytic Capacitor 100μ 16V	C151, 251	OB01272A	Electrolytic Capacitor 100μ 25V	R410, 425	OB05615A	Carbon Re
OB01862A	Electrolytic Capacitor 22μ 16V				426, 460		
OB01780A	Mylar Capacitor 0.1μ 50V J		- Bias Osc. -		466, 474		
					477, 478		
OB09246A	Mica Capacitor 150P 50V J	Q301, 302	OB06100A	Transistor 2SC945 (A)	479, 483		
OB09323A	PP Capacitor 560P 100V J	303			R411	OB01682A	Carbon Re
OB09282A	Ceramic Capacitor 100P 50V K	T301	OB06613A	Osc. Coil	R412, 417	OB05627A	Carbon Re
OB01389A	Electrolytic Capacitor 4.7μ 25V	R301, 302	OB05668A	Carbon Resistor 82K ERD-25T J	429, 452		
		R303, 304	OB09212A	Fail Safe Type Resistor 2.2RDF-25S J	455, 469		
- Line Amp. -		R305	OB01682A	Carbon Resistor 6.8K ERD-25T J	480, 489		
		R310	OB09296A	Fail Safe Type Resistor 39 RSF-½B J	494		
OB01872A	Transistor 2SC945 (L)	R311	OB09295A	Fail Safe Type Resistor 82 RSF-2B J	R414, 456	OB05508A	Carbon Re
		C301	OB05583A	Mylar Capacitor 0.033μ 50V J	R415	OB09328A	Metal Film
		C302, 303	OB09191A	PP Capacitor 4700P 100V G	R416	OB09340A	Metal Film
OB06013A	Transistor 2SA733	C304	OB01402A	Electrolytic Capacitor 4.7μ 25V	R419	OB05626A	Carbon Re
		C305	OB09254A	PP Capacitor 0.068μ 100V J	R420, 421	OB05671A	Carbon Re
OB06181A	Silicon Diode 1SS53				R423	OB09214A	Fail Safe T
			- Logic -		R431, 432	OB01681A	Carbon Re
OB01681A	Carbon Resistor 3.3K ERD-25T J	IC402			439, 445		
		Q401, 403	OB06124B	IC RC4558D	R434	OB05692A	Carbon Re
OB05641A	Carbon Resistor 47K ERD-25T J	411, 416	OB06013A	Transistor 2SA733	R436	OB09314A	Carbon Re
OB05626A	Carbon Resistor 150K ERD-25T J	418, 419			R437	OB09384A	Fail Safe T
		423, 424			R438, 443	OB01857A	Carbon Re
OB05509A	Carbon Resistor 33K ERD-25T J				465, 471		

For Service Manuals Contact
MAURITRON TECHNICAL SERVICES
 8 Cherry Tree Rd. Chinnor

Oxon OX9 4QY

Tel:- 01844-351694 Fax:- 01844-352554

Email:- enquiries@mauritron.co.uk

Schematic Ref. No.	Part No.	Description	Schematic Ref. No.	Part No.	Description
R442	0B01680A	Carbon Resistor 820 ERD-25T J		0B08680B	Heat Sink A (1 pce.)
R453	0B05621A	Carbon Resistor 120K ERD-25T J		0C08144C	Record Spring (1 pce.)
R454, 481	0B09335A	Carbon Resistor 680K ERD-25T J		0B08569C	Record Wire Holder (1 pce.)
R457, 458	0B05622A	Carbon Resistor 2.2K ERD-25T J		0B08570A	Record Spring Holder (1 pce.)
R463, 476	0B01846A	Carbon Resistor 4.7K ERD-25T J		0B08573A	Wire Holder (1 pce.)
R470	0B01684A	Carbon Resistor 470K ERD-25T J		0B08349A	Fuse Clip (UK, Australia & 220V Class 2) (4 pcs.)
R484	0B01683A	Carbon Resistor 15K ERD-25T J		0M03782A	Fuse Label 1A 250V (U.S.A., Canada, Japan & Others) (1 pce.)
C403	0B09286A	Ceramic Capacitor 470P 50V K		0M04100B	Fuse Label 500mA 250V (U.S.A., Canada, Japan & Others) (1 pce.)
C406, 411 412	0B09332A	Electrolytic Capacitor 2.2 μ 25V (LN)		0M04082B	Fuse Label T 125mA 250V (UK, Australia & 220V Class 2) (1 pce.)
C407	0B09251A	Electrolytic Capacitor 33 μ 25V		0M04096B	Fuse Label T 500mA 250V (UK, Australia & 220V Class 2) (1 pce.)
C408	0B09283A	Ceramic Capacitor 220P 50V K		0E00612A	Screw M3x6 Philips Pan Head (2A) (2 pcs.)
C409	0B09345A	Electrolytic Capacitor 3.3 μ 25V (BP)		0E00788A	BT Screw M2x8 Philips Pan Head (1 pce.)
C414	0B09333A	Electrolytic Capacitor 4.7 μ 25V (LN)		0E00831A	BT Screw M3x10 Philips Pan Head (1 pce.)
C415	0B01272A	Electrolytic Capacitor 100 μ 25V		0E00857A	BT Screw M3x6 Philips Binding Head (2 pcs.)
C416	0B01405A	Electrolytic Capacitor 1 μ 50V		0E00507A	Nut Hex. M3 (2 pcs.)
C417	0B01674A	Electrolytic Capacitor 10 μ 25V		0E00117A	Washer 2mm (1 pce.)
C418	0B01676A	Mylar Capacitor 0.056 μ 50V		0E00172A	Washer 3mm Toothed Lock (1 pce.)
C419	0B09292A	Ceramic Capacitor 0.1 μ 50V Z			
C420, 422	0B09290A	Ceramic Capacitor 0.01 μ 50V Z			
C421	0B09368A	Electrolytic Capacitor 22 μ 25V (BP)			
	- Power Supply -				
IC401	0B06237A	Regulator +24V μ A7824			
D401	0B06183A	Diode Bridge RB151			
D402	0B06181A	Silicon Diode 1SS53			
R309	0B09339A	Fail Safe Type Resistor 3.3RSF-25S J			
R401	0B01888A	Carbon Resistor 10K ERD-25T J			
R402	0B01684A	Carbon Resistor 470K ERD-25T J			
C306	0B01870A	Electrolytic Capacitor 1000 μ 25V			
C401, 402	0B01412A	Electrolytic Capacitor 10 μ 16V			
C404	0B03336A	Electrolytic Capacitor 2200 μ 50V			
C405	0B03373A	Electrolytic Capacitor 3300 μ 25V			
	- Miscellaneous -				
	0B07847H	Main P.C.B.			
	0B01857A	Carbon Resistor 1K ERD-25T J (2 pcs.)			
F401	0B03686A	Fuse 1A 250V (Japan)			
F401	0B08374A	Fuse 1A 250V (U.S.A., Canada & Others)			
F401	0B08275A	Fuse T 125mA 250V (UK, Australia & 220V Class 2)			
F402	0B08698A	Fuse 500mA 250V (U.S.A., Canada & Others)			
F402	0B08697A	Fuse 500mA 250V (Japan)			
F402	0B08457A	Fuse T 500mA 250V (UK, Australia & 220V Class 2)			
M2	0B08363A	Spark Killer (Japan)			
M2	0B08342A	Spark Killer (U.S.A. & Canada)			
M2	0B08240U	Spark Killer (UK, Australia & Others)			
M2, 3	0B08445A	Spark Killer (220V Class 2)			
CN1	0B08654A	4P-T Post			
CN2	0B08681A	12P-T Post			
CN3	0B08653A	3P-T Post			
CN4	0B08656A	2P-T Post			
SW301	0B07239A	Record Switch			
	0B07303A	Push Switch (1 pce.)			
	0B08675A	Pin Jack (1 pce.)			
	0B08676A	Heat Sink (1 pce.)			

For Service Manuals Contact
MAURITRON TECHNICAL SERVICES
 8 Cherry Tree Rd, Chinnor
 Oxon OX9 4QY
 Tel: 01844-351694 Fax: 01844-352554
 Email: enquiries@mauritron.co.uk

	Schematic Ref. No.	Part No.	Description	Schematic Ref. No.	Part No.	Description	Schematic Ref. No.	Part
da)	C114, 214	OB01913A	Mylar Capacitor 1800P 50V J	R142, 242	OB05509A	Carbon Resistor 33K ERD-25T J	417, 418	
	C115, 116	OB01412A	Electrolytic Capacitor 10μ 16V	R144, 244	OB09263A	Carbon Resistor 12K ERD-25T J	419, 423	
	117, 123			R145, 245	OB05575A	Carbon Resistor 560 ERD-25T J	424, 425	
ia)	215, 216			R147, 247	OB01679A	Carbon Resistor 100 ERD-25T J	429, 431	
	217, 223			R148, 149	OB01856A	Carbon Resistor 8.2K ERD-25T J	Q402, 406	OB060
	C118, 218	OB09191A	PP Capacitor 4700P 100V G	248, 249			409, 428	
04	C119, 219	OB01804A	Mylar Capacitor 3900P 50V J	R150, 151	OB09331A	Fail Safe Type Resistor 8.2 RDF-25S J	Q404, 410	OB060
	C120, 220	OB09240A	PP Capacitor 0.033μ 100V G	250, 251			412, 415	
	C121, 221	OB01862A	Electrolytic Capacitor 22μ 16V	R152, 252	OB01857A	Carbon Resistor 1K ERD-25T J	420, 421	
	C122, 222	OB05583A	Mylar Capacitor 0.033μ 50V J	R153, 253	OB09306A	Fail Safe Type Resistor 68 RDF-25S J	422, 426	
	C124, 224	OB01603A	Mylar Capacitor 0.1μ 50V K	R163, 263	OB05622A	Carbon Resistor 2.2K ERD-25T J	427, 430	
	C125, 225	OB09327A	Electrolytic Capacitor 0.33μ 50V (LN)	R164, 264	OB05641A	Carbon Resistor 47K ERD-25T J	433	
	C136, 236	OB05885A	Electrolytic Capacitor 100μ 10V	R170, 270	OB01679A	Carbon Resistor 100 ERD-25T J	Q405, 413	OB060
	C137, 237	OB01272A	Electrolytic Capacitor 100μ 25V	C140, 240	OB05652A	Mylar Capacitor 4700P 50V J	Q407	OB060
T J				C141, 145	OB01412A	Electrolytic Capacitor 10μ 16V	Q408, 414	OB060
		- Rec. Amp. -		241, 245			Q432	OB060
T J	Q103, 203	OB01872A	Transistor 2SC945 (L)	C142, 242	OB01862A	Electrolytic Capacitor 22μ 16V	D403-429	OB060
T J	L104, 105	OB00068A	Trap Coil 10.5mH	C146, 147	OB01272A	Electrolytic Capacitor 100μ 25V	R403, 407	OB010
TS J	204, 205			246, 247			408, 413	
	VR102,103	OB07237A	Semi-fixed Volume 50K	C152, 252	OB05653A	Mylar Capacitor 1500P 50V J	418, 422	
T J	104,202						427, 428	
	203,204				- Meter Amp. -		430, 433	
T J	R127, 129	OB01683A	Carbon Resistor 15K ERD-25T J	Q109, 110	OB06100A	Transistor 2SC945 (A)	440, 441	
T J	131, 137			209, 210			448, 468	
T J	227, 229			ZD101,201	OB06191A	Zener Diode 2.7EB	472, 473	
T J	231, 237			D104, 150	OB06181A	Silicon Diode 1SS53	475, 485	
T J	R125, 225	OB09263A	Carbon Resistor 12K ERD-25T J	204, 205			486, 487	
T J	R126, 226	OB05691A	Carbon Resistor 390 ERD-25T J	VR105,205	OB07237A	Semi-fixed Volume 50K	488, 490	
T J	R132, 232	OB05621A	Carbon Resistor 120K ERD-25T J	R154, 159	OB01889A	Carbon Resistor 100K ERD-25T J	492	
(LN)	R133, 233	OB01856A	Carbon Resistor 8.2K ERD-25T J	254, 259			R404, 446	OB010
(N)	R134, 234	OB01857A	Carbon Resistor 1K ERD-25T J	R155, 255	OB09318A	Metal Film Resistor 560K SN14K2E F	447	
	R135, 235	OB05698A	Carbon Resistor 1.5K ERD-25T J	R156, 256	OB09338A	Metal Film Resistor 390K SN14K2E F	R405, 424	OB010
	R136, 168	OB05622A	Carbon Resistor 2.2K ERD-25T J	R157, 158	OB01888A	Carbon Resistor 10K ERD-25T J	435, 449	
	236, 268			257, 258			450, 451	
	R138, 238	OB01888A	Carbon Resistor 10K ERD-25T J	R160, 260	OB05691A	Carbon Resistor 390 ERD-25T J	459, 461	
	C126, 226	OB05530A	Mylar Capacitor 6800P 50V J	R161, 261	OB09213A	Fail Safe Type Resistor 150 RDF-25S J	462, 467	
	C127, 227	OB05814A	Mylar Capacitor 8200P 50V J	C148, 248	OB01405A	Electrolytic Capacitor 1μ 50V	493	
	C128, 228	OB05550A	Mylar Capacitor 1000P 50V J	C149, 249	OB09218A	Electrolytic Capacitor 47μ 16V (LN)	R406, 491	OB050
	C129, 229	OB01400A	Electrolytic Capacitor 100μ 16V	C150, 250	OB09219A	Electrolytic Capacitor 6.8μ 16V (LN)	R409, 464	OB050
	C133, 233	OB01862A	Electrolytic Capacitor 22μ 16V	C151, 251	OB01272A	Electrolytic Capacitor 100μ 25V	R410, 425	OB050
	C134, 135	OB01780A	Mylar Capacitor 0.1μ 50V J				426, 442	
	234, 235				- Bias Osc. -		460, 466	
	C138, 238	OB09246A	Mica Capacitor 150P 50V J	Q301, 302	OB06100A	Transistor 2SC945 (A)	474, 477	
	C139, 239	OB09323A	PP Capacitor 560P 100V J	303			478, 479	
	C153, 253	OB09282A	Ceramic Capacitor 100P 50V K	T301	OB06613A	Osc. Coil	483	
	C154, 254	OB01389A	Electrolytic Capacitor 4.7μ 25V	R301, 302	OB05668A	Carbon Resistor 82K ERD-25T J	R411, 439	OB010
		- Line Amp. -		R303, 304	OB09212A	Fail Safe Type Resistor 2.2 RDF-25S J	R412, 417	OB050
T J	Q104, 105	OB01872A	Transistor 2SC945 (L)	R305	OB01682A	Carbon Resistor 6.8K ERD-25T J	429, 452	
	107, 204			R310	OB09296A	Fail Safe Type Resistor 39 RSF-1/2B J	455, 469	
	205, 207			R311	OB09295A	Fail Safe Type Resistor 82 RSF-2B J	480, 489	
E F	Q106, 108	OB06013A	Transistor 2SA733	C301	OB05583A	Mylar Capacitor 0.033μ 50V J	494	
T J	206, 208			C302, 303	OB09191A	PP Capacitor 4700P 100V G	R414, 456	OB050
T J	D101, 102	OB06181A	Silicon Diode 1SS53	C304	OB01402A	Electrolytic Capacitor 4.7μ 25V	R415	OB090
SS J	201, 202			C305	OB09254A	PP Capacitor 0.068μ 100V J	R416	OB090
T J	R139, 146	OB01681A	Carbon Resistor 3.3K ERD-25T J		- Logic -		R419	OB050
T J	239, 246			IC402	OB06124B	IC RC4558D	R420, 421	OB050
(LN)	R140, 240	OB05641A	Carbon Resistor 47K ERD-25T J	Q401, 403	OB06013A	Transistor 2SA733	R423	OB090
	R141, 143	OB05626A	Carbon Resistor 150K ERD-25T J	411, 416			R431, 432	OB010
	241, 243						445	
							R434	OB050
							R436	OB090
							R437	OB090

Part No.	Description	Schematic Ref. No.	Part No.	Description	Schematic Ref. No.	Part No.	
0B05509A	Carbon Resistor 33K ERD-25T J	417, 418			R438	0B05614A	Carbon F
0B09263A	Carbon Resistor 12K ERD-25T J	419, 423			R443, 465	0B01857A	Carbon F
0B05575A	Carbon Resistor 560 ERD-25T J	424, 425			471		
0B01679A	Carbon Resistor 100 ERD-25T J	429, 431			R453	0B05621A	Carbon F
0B01856A	Carbon Resistor 8.2K ERD-25T J	Q402, 406	0B06069A	Transistor 2SB564	R454, 481	0B09335A	Carbon F
		409, 428			R457, 458	0B05622A	Carbon F
0B09331A	Fail Safe Type Resistor 8.2 RDF-25S J	Q404, 410	0B06100A	Transistor 2SC945 (A)	R463, 476	0B01846A	Carbon F
		412, 415			R470	0B01684A	Carbon F
0B01857A	Carbon Resistor 1K ERD-25T J	420, 421			R484	0B01683A	Carbon F
0B09306A	Fail Safe Type Resistor 68 RDF-25S J	422, 426			C403	0B09286A	Ceramic
0B05622A	Carbon Resistor 2.2K ERD-25T J	427, 430			C406, 411	0B09332A	Electroly
0B05641A	Carbon Resistor 47K ERD-25T J	433			412		
0B01679A	Carbon Resistor 100 ERD-25T J	Q405, 413	0B06066A	Transistor 2SD471	C407	0B09251A	Electroly
0B05652A	Mylar Capacitor 4700P 50V J	Q407	0B06020A	Transistor 2SC1096	C408	0B09283A	Ceramic
0B01412A	Electrolytic Capacitor 10μ 16V	Q408, 414	0B06012A	Transistor 2SA634	C409	0B09345A	Electroly
		Q432	0B06251A	Transistor 2SC945A (Q)	C414	0B09333A	Electroly
0B01862A	Electrolytic Capacitor 22μ 16V	D403-429	0B06181A	Silicon Diode 1SS53 (27 pcs.)	C415	0B01272A	Electroly
0B01272A	Electrolytic Capacitor 100μ 25V	R403, 407	0B01889A	Carbon Resistor 100K ERD-25T J	C416	0B01405A	Electroly
		408, 413			C417	0B01674A	Electroly
0B05653A	Mylar Capacitor 1500P 50V J	418, 422			C418	0B01676A	Mylar Ca
		427, 428			C419	0B09292A	Ceramic
		430, 433			C420	0B09290A	Ceramic
		440, 441			C421	0B09368A	Electroly
		448, 468					
		472, 473					
0B06100A	Transistor 2SC945 (A)	475, 485					
		486, 487					
0B06191A	Zener Diode 2.7EB	488, 490					
0B06181A	Silicon Diode 1SS53	492					
		492					
0B07237A	Semi-fixed Volume 50K	R404, 446	0B01887A	Carbon Resistor 5.6K ERD-25T J	IC401	0B06237A	Regulat
0B01889A	Carbon Resistor 100K ERD-25T J	447			D401	0B06183A	Diode Br
		447			D402	0B06181A	Silicon D
0B09318A	Metal Film Resistor 560K SN14K2E F	R405, 424	0B01888A	Carbon Resistor 10K ERD-25T J	R309	0B09339A	Fail Safe
0B09338A	Metal Film Resistor 390K SN14K2E F	435, 449			R401	0B01888A	Carbon F
0B01888A	Carbon Resistor 10K ERD-25T J	450, 451			R402	0B01684A	Carbon F
		459, 461			R402	0B01684A	Carbon F
0B05691A	Carbon Resistor 390 ERD-25T J	462, 467			C306	0B01870A	Electroly
0B09213A	Fail Safe Type Resistor 150 RDF-25S J	493			C401, 402	0B01412A	Electroly
0B01405A	Electrolytic Capacitor 1μ 50V	R406, 491	0B05575A	Carbon Resistor 560 ERD-25T J	C404	0B09336A	Electroly
0B09218A	Electrolytic Capacitor 47μ 16V (LN)	R409, 464	0B05509A	Carbon Resistor 33K ERD-25T J	C405	0B09373A	Electroly
0B09219A	Electrolytic Capacitor 6.8μ 16V (LN)	R410, 425	0B05615A	Carbon Resistor 22K ERD-25T J			
0B01272A	Electrolytic Capacitor 100μ 25V	426, 442					
		460, 466					
		474, 477					
		478, 479					
		483					
0B06100A	Transistor 2SC945 (A)	R411, 439	0B01682A	Carbon Resistor 6.8K ERD-25T J	F401	0B08686A	Fuse
		R412, 417	0B05627A	Carbon Resistor 330K ERD-25T J	F401	0B08374A	Fuse (U.S.A.,
0B06613A	Osc. Coil	429, 452			F401	0B08275A	Fuse (UK, Au
0B05668A	Carbon Resistor 82K ERD-25T J	455, 469			F402	0B08698A	Fuse (U.S.A.,
0B09212A	Fail Safe Type Resistor 2.2 RDF-25S J	480, 489			F402	0B08697A	Fuse (Japan)
0B01682A	Carbon Resistor 6.8K ERD-25T J	494			F402	0B08457A	Fuse (UK, Au
0B09296A	Fail Safe Type Resistor 39 RSF-1/2B J	R414, 456	0B05508A	Carbon Resistor 56K ERD-25T J	M2	0B08363A	Spark K
0B09295A	Fail Safe Type Resistor 82 RSF-2B J	R415	0B09328A	Metal Film Resistor 9.1K SN14K2E F	M2	0B08342A	Spark K
0B05583A	Mylar Capacitor 0.033μ 50V J	R416	0B09340A	Metal Film Resistor 15K SN14K2E F	M2	0B08240U	Spark K
0B09191A	PP Capacitor 4700P 100V G	R419	0B05626A	Carbon Resistor 150K ERD-25T J			
0B01402A	Electrolytic Capacitor 4.7μ 25V	R420, 421	0B05671A	Carbon Resistor 2.2M ERD-25T J			
0B09254A	PP Capacitor 0.068μ 100V J	R423	0B09214A	Fail Safe Type Resistor 1 RDF-25S J			
		R431, 432	0B01681A	Carbon Resistor 3.3K ERD-25T J			
		445					
		R434	0B05692A	Carbon Resistor 68K ERD-25T J	M2, 3	0B08445A	Spark K
0B06124B	IC RC4558D	R436	0B09314A	Carbon Resistor 5.1K ERD-25T J	CN1	0B08654A	4P-T Po
0B06013A	Transistor 2SA733	R437	0B09049A	Fail Safe Type Resistor 22 ERD-14F J	CN2	0B08681A	12P-T P
					CN3	0B08653A	3P-T Po
					CN4	0B08656A	2P-T Po
					SW301	0B07239A	Record

	Schematic Ref. No.	Part No.	Description	Schematic Ref. No.	Part No.	Description
	R438	0B05614A	Carbon Resistor 1.8K ERD-25T J		0B07303A	Push Switch (1 pce.)
	R443, 465 471	0B01857A	Carbon Resistor 1K ERD-25T J		0B08675A	Pin Jack (1 pce.)
	R453	0B05621A	Carbon Resistor 120K ERD-25T J		0B08676A	Heat Sink (1 pce.)
	R454, 481	0B09335A	Carbon Resistor 680K ERD-25T J		0B08680B	Heat Sink A (1 pce.)
	R457, 458	0B05622A	Carbon Resistor 2.2K ERD-25T J		0C08144C	Record Spring (1 pce.)
A)	R463, 476	0B01846A	Carbon Resistor 4.7K ERD-25T J		0B08569C	Record Wire Holder (1 pce.)
	R470	0B01684A	Carbon Resistor 470K ERD-25T J		0B08570A	Record Spring Holder (1 pce.)
	R484	0B01683A	Carbon Resistor 15K ERD-25T J		0B08573A	Wire Holder (1 pce.)
	C403	0B09286A	Ceramic Capacitor 470P 50V K		0B08349A	Fuse Clip
	C406, 411 412	0B09332A	Electrolytic Capacitor 2.2μ 25V (LN)		0M03782A	(UK, Australia & 220V Class 2)(4 pcs.) Fuse Label 1A 250V
	C407	0B09251A	Electrolytic Capacitor 33μ 25V		0M04100B	(U.S.A., Canada, Japan & Others)(1 pce.) Fuse Label 500mA 250V
	C408	0B09283A	Ceramic Capacitor 220P 50V K		0M04082B	(U.S.A., Canada, Japan & Others)(1 pce.) Fuse Label T 125mA 250V
(Q)	C409	0B09345A	Electrolytic Capacitor 3.3μ 25V (BP)		0M04096B	(UK, Australia & 220V Class 2)(1 pce.) Fuse Label T 500mA 250V
7 pcs.)	C414	0B09333A	Electrolytic Capacitor 4.7μ 25V (LN)		0E00612A	(UK, Australia & 220V Class 2)(1 pce.) Screw M3x6 Philips Pan Head (2A)
D-25T J	C415	0B01272A	Electrolytic Capacitor 100μ 25V		0E00788A	BT Screw M2x8 Philips Pan Head (2 pcs.)
	C416	0B01405A	Electrolytic Capacitor 1μ 50V		0E00831A	BT Screw M3x10 Philips Pan Head (1 pce.)
	C417	0B01674A	Electrolytic Capacitor 10μ 25V		0E00857A	BT Screw M3x6 Philips Binding Head (2 pcs.)
	C418	0B01676A	Mylar Capacitor 0.056μ 50V		0E00507A	Nut Hex. M3 (2 pcs.)
	C419	0B09292A	Ceramic Capacitor 0.1μ 50V Z		0E00117A	Washer 2mm (1 pce.)
	C420	0B09290A	Ceramic Capacitor 0.01μ 50V Z		0E00172A	Washer 3mm Toothed Lock (1 pce.)
	C421	0B09368A	Electrolytic Capacitor 22μ 25V (BP)			
		- Power Supply -				
	IC401	0B06237A	Regulator +24V μA7824			
	D401	0B06183A	Diode Bridge RB151			
	D402	0B06181A	Silicon Diode 1SS53			
D-25T J	R309	0B09339A	Fail Safe Type Resistor 3.3 RSF-25S J			
	R401	0B01888A	Carbon Resistor 10K ERD-25T J			
D-25T J	R402	0B01684A	Carbon Resistor 470K ERD-25T J			
	C306	0B01870A	Electrolytic Capacitor 1000μ 25V			
	C401, 402	0B01412A	Electrolytic Capacitor 10μ 16V			
	C404	0B09336A	Electrolytic Capacitor 2200μ 50V			
	C405	0B09373A	Electrolytic Capacitor 3300μ 25V			
		- Miscellaneous -				
		0B07847D	Main P.C.B.			
		0B01857A	Carbon Resistor 1K ERD-25T J (2 pcs.)			
	F401	0B08686A	Fuse 1A 250V (Japan)			
	F401	0B08374A	Fuse 1A 250V (U.S.A., Canada & Others)			
	F401	0B08275A	Fuse T 125mA 250V (UK, Australia & 220V Class 2)			
	F402	0B08698A	Fuse 500mA 250V (U.S.A., Canada & Others)			
	F402	0B08697A	Fuse 500mA 250V (Japan)			
	F402	0B08457A	Fuse T 500mA 250V (UK, Australia & 220V Class 2)			
	M2	0B08363A	Spark Killer (Japan)			
	M2	0B08342A	Spark Killer (U.S.A. & Canada)			
	M2	0B08240U	Spark Killer (UK, Australia & Others)			
	M2, 3	0B08445A	Spark Killer (220V Class 2)			
	CN1	0B08654A	4P-T Post			
	CN2	0B08681A	12P-T Post			
	CN3	0B08653A	3P-T Post			
	CN4	0B08656A	2P-T Post			
	SW301	0B07239A	Record Switch			

For Service Manuals Contact
MAURITRON TECHNICAL SERVICES
8 Cherry Tree Rd, Chinnor
Oxon OX9 4QY
Tel: 01844-351694 Fax: 01844-352554
Email: enquiries@mauritron.co.uk

9. MECHANISM ASSY AND PARTS LIST

9.1. Synthesis

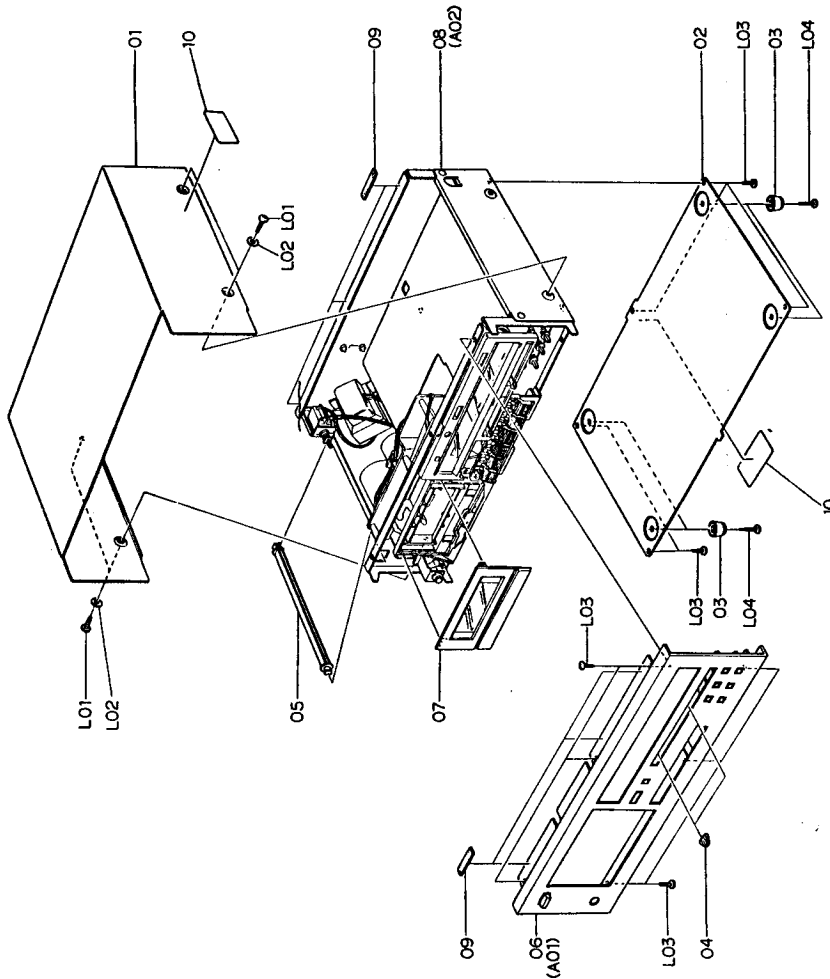

Fig. 9.1

Schematic Ref. No.	Part No.	Description	Qty	Schematic Ref. No.	Part No.	Description	Qty
01	0H03768A	Synthesis Top Cover Ass'y	1		JA03631A	Synthesis Mechanism Ass'y (Australia)	1
02	0H03769B	Bottom Cover Ass'y	1		JA03632A	Synthesis Mechanism Ass'y (UK)	1
03	0J03564A	Leg T-H	1		JA03633A	Synthesis Mechanism Ass'y (Others)	1
04	0H03794B	Volume Knob	2	09	0H03781A	Cushion	6
05	0J04066C	Power Switch Joint Bar	1	10	0M04101A	Caution Label	2
06	HA03871A	Front Panel Ass'y	1	L01	0E00858A	BT Screw M4x6 Phillips Binding Head (Black Chromate)	4
07	HA03872A	Cassette Case Cover Ass'y (U.S.A. & Canada)	1	L02	0E00736A	Washer 4mm (Black Chromate)	4
08	JA03629A	Synthesis Mechanism Ass'y (U.S.A. & Canada)	1	L03	0E00857A	BT Screw M3x6 Phillips Binding Head	11
	JA03628A	Synthesis Mechanism Ass'y (Japan)	1	L04	0E00865A	BT Screw M3x10 Phillips Binding Head	4
	JA03630A	Synthesis Mechanism Ass'y (220V Class 2)	1				

9.2. Front Panel Ass'y (A01)

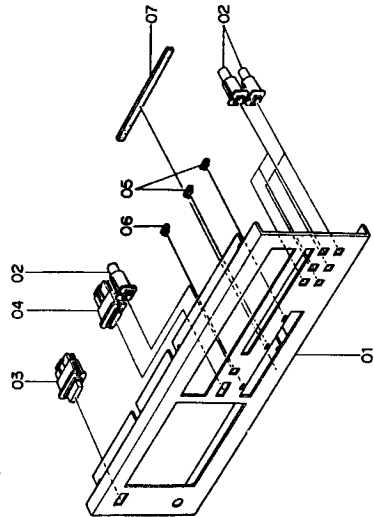

Fig. 9.2

9.3. Synthesis Mechanism Ass'y (A02)

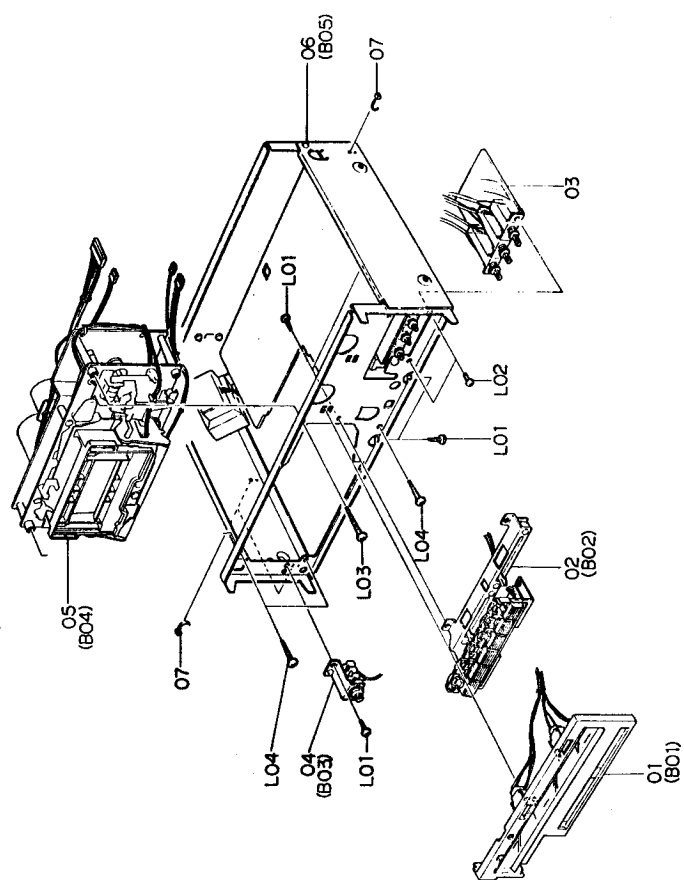

Fig. 9.3

9.4. Meter Escutcheon Ass'y (B01)

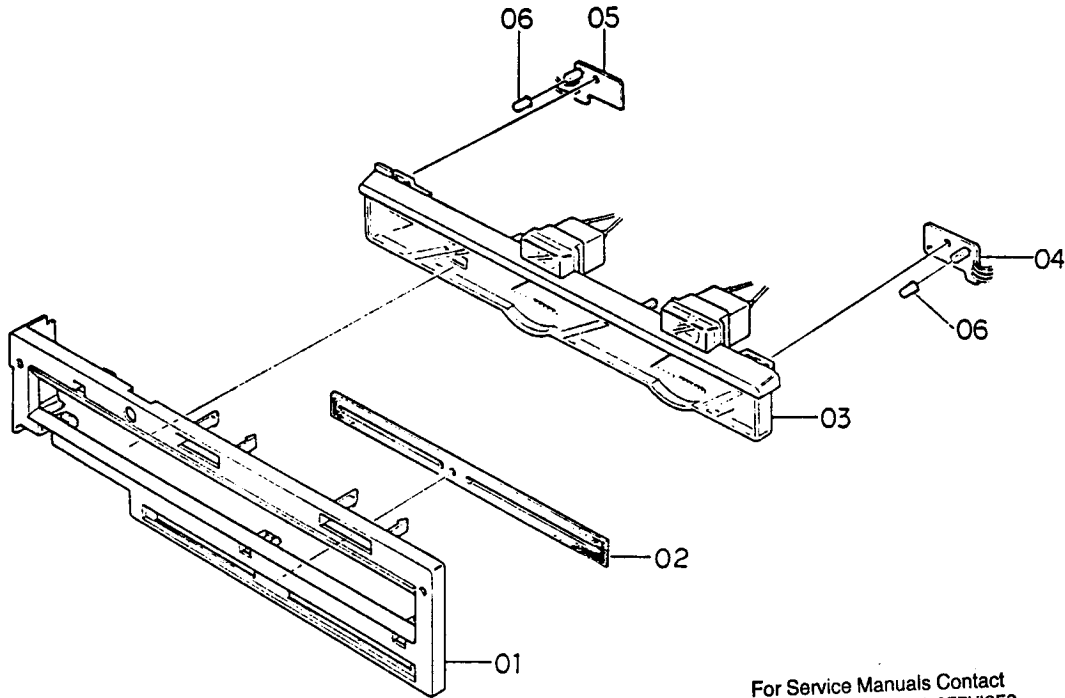

Fig. 9.4

For Service Manuals Contact
MAURITRON TECHNICAL SERVICES
 8 Cherry Tree Rd, Chinnor
 Oxon OX9 4QY
 Tel:- 01844-351694 Fax:- 01844-352554
 Email:- enquiries@mauritron.co.uk

Schematic Ref. No.	Part No.	Description	Q'ty	Schematic Ref. No.	Part No.	Description	Q'ty
A01	HA03871A	Front Panel Ass'y	1	06	JA03611A	Chassis Ass'y (U.S.A. & Canada)	1
01	0H03795B	Front Panel	1		JA03610A	Chassis Ass'y (Japan)	1
02	HA03873A	Push Button Ass'y C	7		JA03612A	Chassis Ass'y (220V Class 2)	1
03	HA03874A	Push Button Ass'y D	1		JA03613A	Chassis Ass'y (Australia)	1
04	HA03875A	Eject Button Ass'y	1		JA03614A	Chassis Ass'y (UK)	1
05	0H03744A	Green Lens	2		JA03615A	Chassis Ass'y (Others)	1
06	0H03745A	Orange Lens	1	07	0B08515A	Insu-Lock	18
07	0J04094A	Control Button Pad	1	L01	0E00857A	BT Screw M3x6 Philips Binding Head	5
-	0J04081A	Adhesive Tape 55x6	5	L02	0E00502A	Screw M3x5 Philips Pan Head	2
-	0J04082A	Adhesive Tape 30x6	2	L03	0E00878A	BT Screw M4x20 Philips Binding Head	1
A02	JA03629A	Synthesis Mechanism Ass'y (U.S.A. & Canada)	1	L04	0E00867A	BT Screw M4x15 Philips Binding Head	3
	JA03628A	Synthesis Mechanism Ass'y (Japan)	1	B01	HA03851A	Meter Escutcheon Ass'y	1
	JA03630A	Synthesis Mechanism Ass'y (220V Class 2)	1	01	0H03770B	Meter Escutcheon	1
	JA03631A	Synthesis Mechanism Ass'y (Australia)	1	02	0H03786A	Volume Cover	1
	JA03632A	Synthesis Mechanism Ass'y (UK)	1	03	BA04110B	Meter Ass'y	1
	JA03633A	Synthesis Mechanism Ass'y (Others)	1	04	BA04124A	Lamp P.C.B. R Ass'y	1
01	HA03851A	Meter Escutcheon Ass'y	1	05	BA04125A	Lamp P.C.B. L Ass'y	1
02	JA03627A	Control Switch Holder Ass'y	1	06	0H03785A	Filter Cover	2
03	BA04127A	Switch P.C.B. Ass'y	1	-	0H03771B	Aluminum Seal	1
04	JA03616A	Headphone Jack Ass'y	1				
05	CA08112A	Mechanism Ass'y 480	1				

9.5. Control Switch Holder Ass'y (B02)

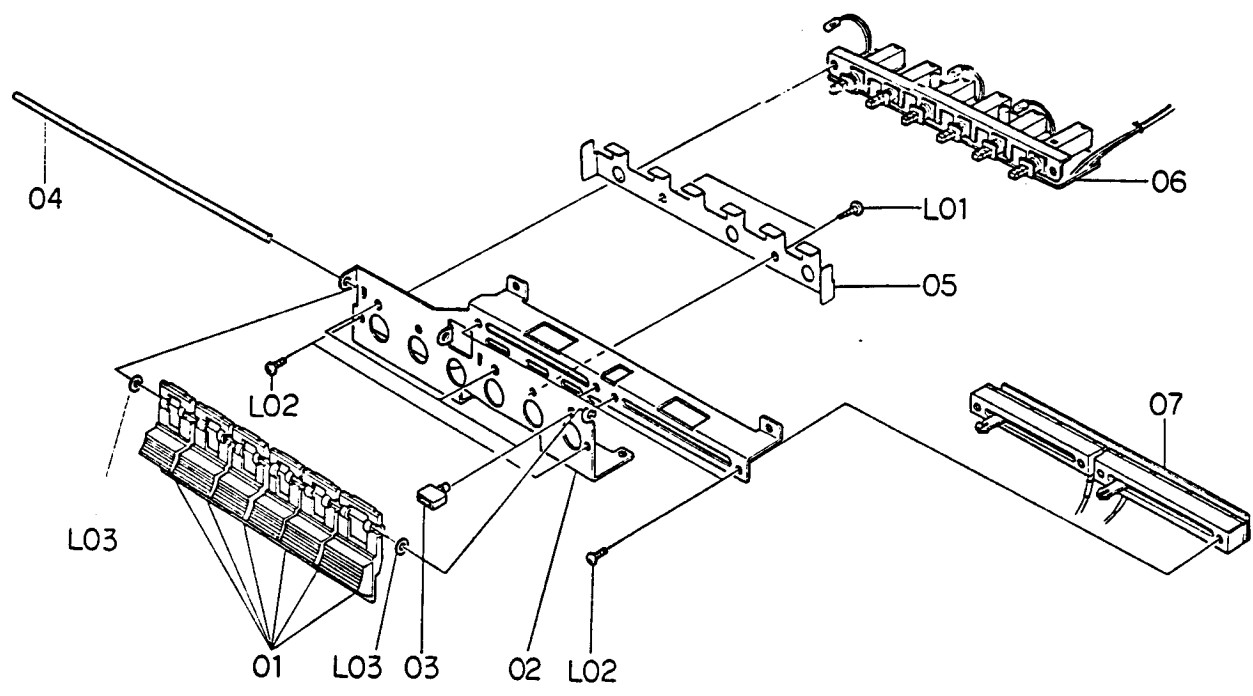

Fig. 9.5

9.6. Headphone Jack Ass'y (B03)

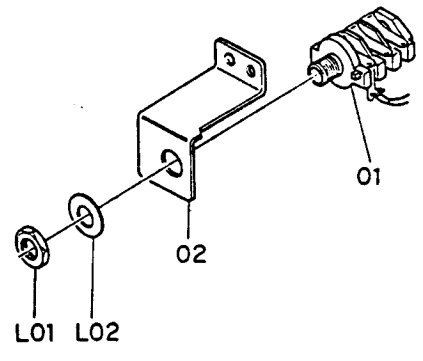
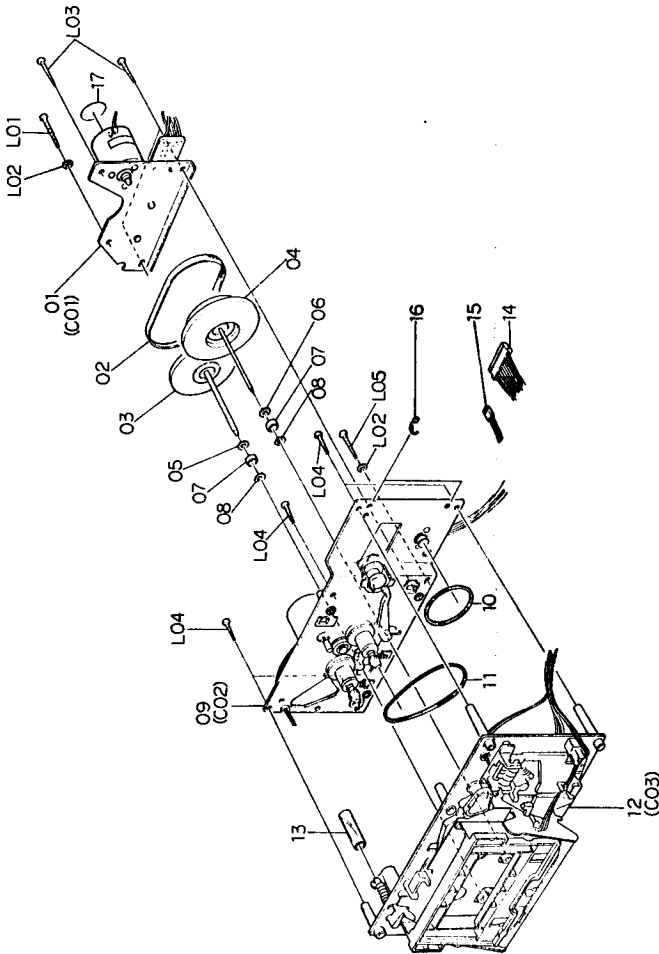

Fig. 9.6

Schematic Ref. No.	Part No.	Description	Q'ty	Schematic Ref. No.	Part No.	Description	Q'ty
B02	JA03627A	Control Switch Holder Ass'y	1	B03	JA03616A	Headphone Jack Ass'y	1
01	0H03793A	Control Button	6	01	0B08511A	Headphone Jack	1
02	0J04071C	Control Switch Holder	1	02	0J04070A	Headphone Jack Holder	1
03	0J04072B	Lamp Cover	3	L01	-	Jack Nut	(1)
04	0J04073A	Control Button Shaft	1	L02	-	Jack Washer	(1)
05	0J04074D	Control Button Spring	1				
06	BA04113A	Control Switch P.C.B. Ass'y	1				
07	BA04114A	Volume P.C.B. Ass'y	1				
L01	0E00857A	BT Screw M3x6 Philips Binding Head	2				
L02	0E00502A	Screw M3x5 Philips Pan Head	6				
L03	0E00117A	Washer 2mm	2				

9.7. Mechanism Assy 480 (B04)



For Service Manuals Contact
MAURITRON TECHNICAL SERVICES
 8 Cherry Tree Rd, Chinnor
 Oxon OX9 4QY
 Tel:- 01844-351694 Fax:- 01844-352554
 Email:- enquiries@maurtron.co.uk

Fig. 9.7

Schematic Ref. No.	Part No.	Description	Q'ty	Schematic Ref. No.	Part No.	Description	Q'ty
B04	CA08112A	Mechanism Assy 480	1	L03	0E00833A	BT Screw M3x20 Phillips Pan Head	3
01	CA08109A	Flywheel Holder Assy	1	L04	0E00883A	BT Screw M3x18 Phillips Pan Head	5
02	0C08096C	Capstan Belt	1	L05	0E00835A	BT Screw M3x25 Phillips Pan Head	1
03	CA08113A	Supply Flywheel B Assy	1				
04	CA08107A	Take-up Flywheel B Assy	1				
05	0C08021B	Thrust Washer 3.1mm	1				
06	0C08020B	Thrust Washer 2.6mm	1				
07	0C08069C	Flange Thrust Cap	2				
08	0C08022B	Sub Mechanism Chassis Assy	1				
09	CA08108A	Counter Belt B	1				
10	0C08098B	Control Motor Belt	1				
11	0C08099B	Main Mechanism Chassis Assy	1				
12	CA08110A	Lid Arm Spring Tube	1				
13	0C08151A	12P-H Connector	1				
14	0B08671B	3P-H Connector	1				
15	0B08672B	Insu-Lock	8				
16	0B08515A	Motor Label 730	1				
17	0M03902A	BT Screw M3x30 Phillips Pan Head	1				
L01	0E00834A	Washer 3mm	2				

9.10. Sub Mechanism Chassis Ass'y (C02)

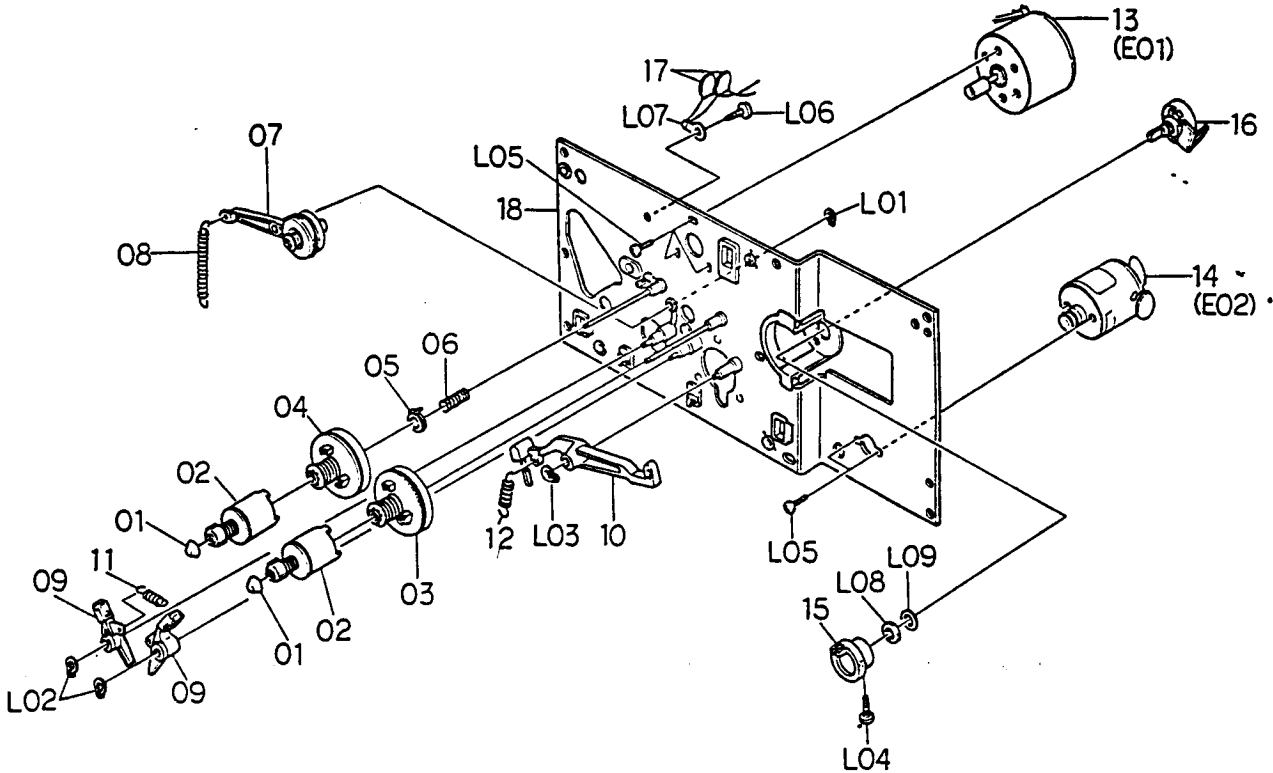

Fig. 9.10

Schematic Ref. No.	Part No.	Description	Q'ty	Schematic Ref. No.	Part No.	Description	Q'ty
C02	CA08108A	Sub Mechanism Chassis Ass'y	1	L06	0E00843A	BT Screw M2.6x4 Philips Pan Head	1
01	0C08039B	Reel Hub Head	2	L07	0E00037A	Earth Lug B-5	1
02	CA08038B	Reel Hub B Ass'y	2	L08	-	Volume Nut	(1)
03	CA08037A	Reel Hub Take-up Ass'y	1	L09	-	Volume Washer	(1)
04	CA08064A	Reel Hub Supply Ass'y	1				
05	CA08039A	Back Tension Ass'y	1				
06	0C08178A	Back Tension Spring	1				
07	CA08040A	Idler Ass'y	1				
08	0C08127B	Idler Arm Spring	1				
09	CA08042A	Brake Arm Ass'y	2				
10	0C08030C	Brake Drive Arm	1				
11	0C08029A	Brake Arm Spring	1				
12	0C08128A	Brake Drive Arm Spring	1				
13	CA08117B	Reel Motor Ass'y	1				
14	CA08124A	Control Motor Ass'y	1				
15	0C08053B	Volume Coupler	1				
16	0B07240A	Volume Control 10 K Ω (B)	1				
17	0B09091A	Ceramic Capacitor 0.01 μ 50V	2				
18	CA08041A	Sub Chassis Ass'y	1				
L01	0E00842A	Stopper Ring 2mm	1				
L02	0E00837A	Stopper Ring 3mm	2				
L03	0E00838A	Stopper Ring 4mm	1				
L04	0E00859A	BT Screw M2.6x6 Philips Binding Head	1				
L05	0E00226A	Screw M2.6x4 Philips Pan Head	5				

For Service Manuals Contact
MAURITRON TECHNICAL SERVICES
 8 Cherry Tree Rd, Chinnor
 Oxon OX9 4QY
 Tel: 01844-351694 Fax: 01844-352554
 Email: enquiries@mauritron.co.uk

480

Schematic Ref. No.	Part No.	Description	Q'ty	Schematic Ref. No.	Part No.	Description	Q'ty
C03	CA08110A	Main Mechanism Chassis Ass'y	1	L08	0E00876A	BT Screw M2.6x8 Philips Pan Head	11
01	CA08141A	Cassette Case Holder L Ass'y	1	L09	0C08060B	Height Adjustment Nut	2
02	CA08022A	Cassette Case Holder R Ass'y	1	L10	0E00142A	Washer 2.6mm	2
03	CA08111A	Cassette Case Ass'y	1	L11	0E00879A	BT Screw M2x15 Philips Pan Head	1
04	0C08019I	Cover Plate	1				
05	0M03977A	Cassette Viewer Label	1	L12	0E00838A	Stopper Ring 4mm	3
06	CA08120A	Head Mount Base Ass'y	1	L13	0E00846A	BT Screw M3x8 Philips Pan Head	3
07	0C08121A	Supply Pressure Roller Spring	2				
08	CA08053B	Supply Pressure Roller Ass'y	1	L14	0E00895A	Earth Lug 3mm	2
09	0C08122B	Supply Pressure Roller Thrust Spring	1				
10	CA08079B	Take-up Pressure Roller Ass'y	1				
11	0C08183B	Take-up Pressure Roller Thrust Spring	1				
12	0C08182A	Pressure Roller Drive Bar	1				
13	CA08121A	Head Base Ass'y C	1				
14	0C08086B	Head Base Roller	3				
15	0C08050B	Record Sensor	1				
16	0C08051E	Cassette Hold Arm	1				
17	0C08120A	Cassette Hold Arm Spring	1				
18	CA08027A	Head Base Drive Arm Ass'y	1				
19	0C08143C	Head Base Drive Arm Spring	1				
20	CA08025A	Record Arm Ass'y	1				
21	0C08038D	Record Trigger	1				
22	0C08112A	Flip-Flop Spring	1				
23	CA08026A	Pressure Roller Drive Arm Ass'y	1				
24	0C08071D	Counter Reset Arm	1				
25	0C08124B	Eject Linkage Wire	1				
26	0C08057D	Eject Arm	1				
27	0C08078B	Arm Shaft	1				
28	CA08119A	Auto Shut-off Ass'y	1				
29	CA08020A	Counter Ass'y	1				
30	0C08097B	Counter Belt A	1				
31	0C08067C	Eject Stopper	1				
32	0C08134C	Eject Stopper Spring	1				
33	0C08119A	Record Protector	1				
34	0C08194C	Damper Lock Arm	1				
35	0C08153A	Damper Arm Spring Tube	1				
36	CA08030A	Pneumatic Damper Ass'y	1				
37	CA08023A	Supply Capstan Flange Ass'y	1				
38	CA08024A	Take-up Capstan Flange Ass'y	1				
39	0C08186A	Cam Drive Gear	1				
40	0C08029H	Control Cam	1				
41	0C08152A	Counter-Load Arm Spring Tube	1				
42	0C08117A	Counter-Load Arm Spring	1				
43	CA08028A	Counter-Load Arm Ass'y	1				
44	0C08123B	Record Switch Linkage Wire	1				
45	0C08037E	Record Arm B	1				
46	0C08116A	Record Arm Spring	2				
47	CA08072A	Main Chassis Ass'y	1				
48	0C08225A	Shield Plate	1				
L01	0E00837A	Stopper Ring 3mm	13				
L02	0E00832A	BT Screw M3x14 Philips Pan Head	2				
L03	0E00834A	BT Screw M3x30 Philips Pan Head	2				
L04	0E00831A	BT Screw M3x10 Philips Pan Head	4				
L05	0E00254A	Washer 3.1mm Plastics	2				
L06	0E00222A	E-Ring 2mm	2				
L07	0E00839A	Stopper Ring 2.5mm	2				

9.11. Main Mechanism Chassis Ass'y (C03)

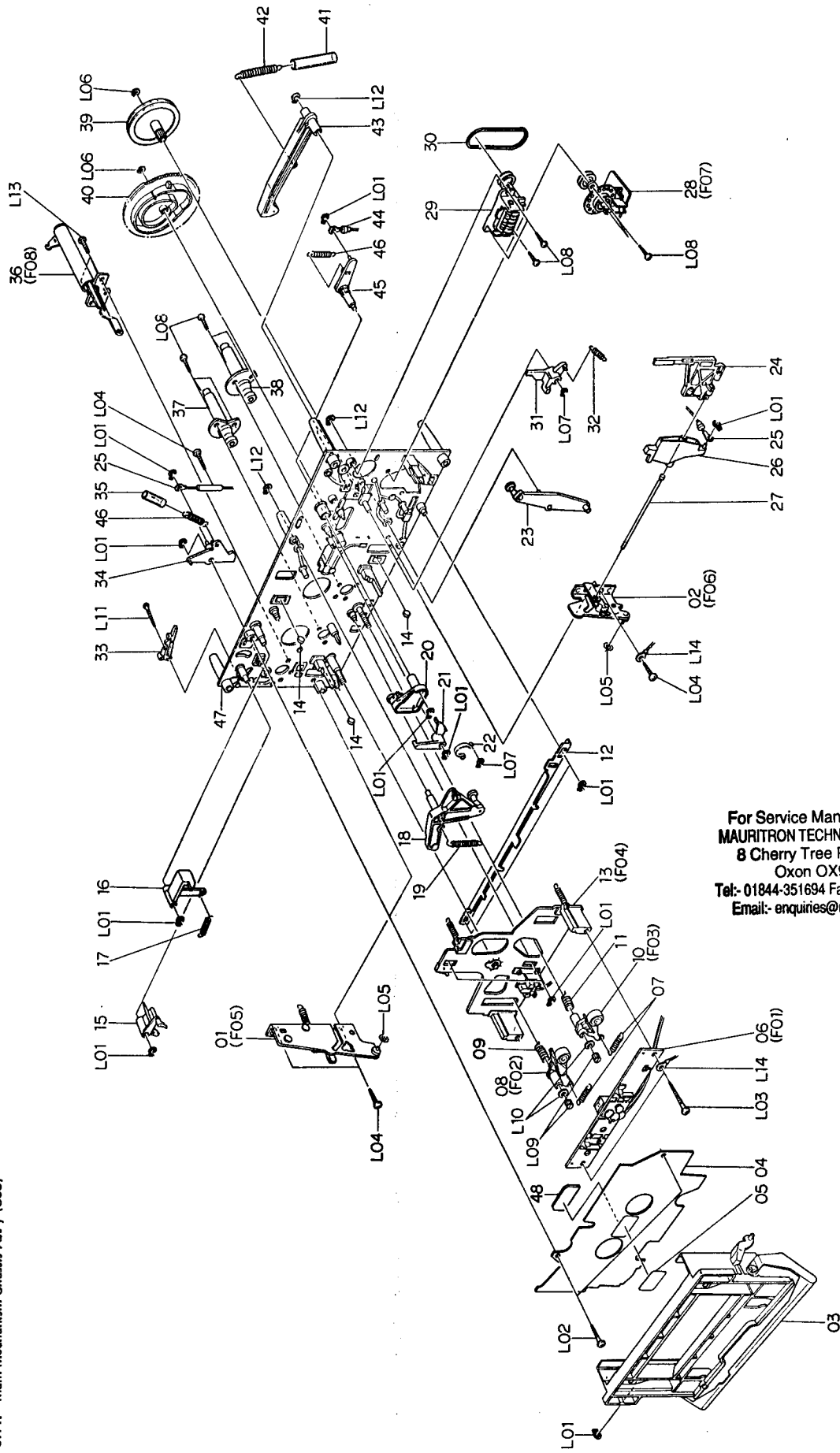

Fig. 9.11

For Service Manuals Contact
MAURITRON TECHNICAL SERVICES
 8 Cherry Tree Rd, Chinnor
 Oxon OX9 4QY
 Tel:- 01844-351694 Fax:- 01844-352554
 Email:- enquiries@mauritron.co.uk

9.12. Rear Panel Assy (D01)

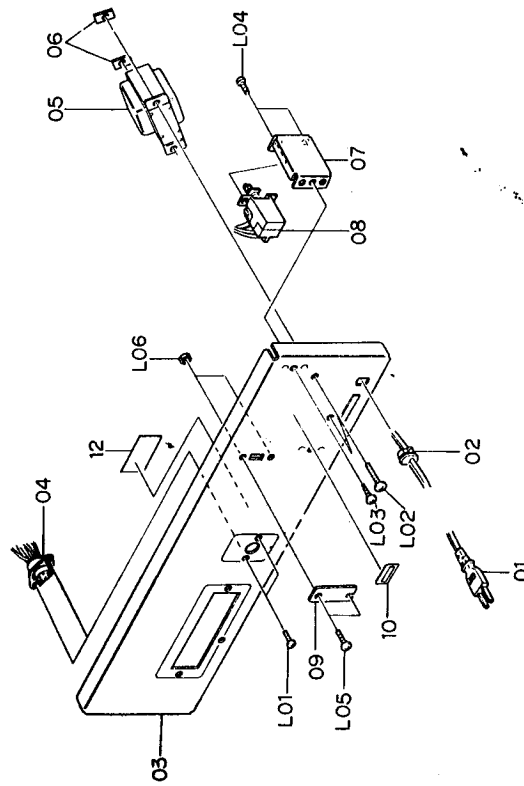
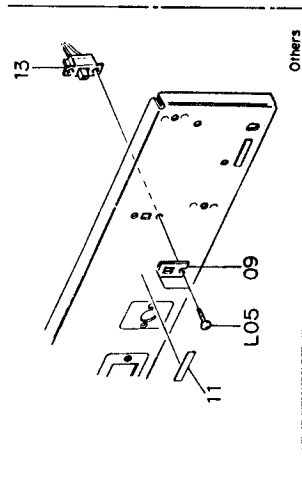

Fig. 9.12

Schematic Ref. No.	Part No.	Description	Q'ty	Schematic Ref. No.	Part No.	Description	Q'ty
D01	HA03856A	Rear Panel Assy (U.S.A. & Canada)	1	L06	0E00507A	Nut Hex. M3	2
	HA03855A	Rear Panel Assy (Japan)	1		0Q03644A	Chobert Rivet	2
	HA03857A	Rear Panel Assy (220V Class 2)	1			*: Depends on the versions.	
	HA03858A	Rear Panel Assy (Australia)	1	E01	CA08117B	Reel Motor Assy	1
	HA03859A	Rear Panel Assy (UK)	1	01	0C08218A	Reel Motor	1
01	HA03860A	Rear Panel Assy (Others)	1	02	0C08063F	Reel Motor Pulley	1
	0B08533A	Power Cord (U.S.A., Canada & Others)	1	E02	CA08124A	Control Motor Assy	1
	0B08219B	Power Cord (Japan)	1	01	0C08137A	Control Motor	1
	0B08093U	Power Cord (220V Class 2)	1	02	0C08064A	Control Motor Pulley	1
	0B08666A	Power Cord (Australia)	1	03	0E09292A	Ceramic Capacitor 0.1µ 50V	2
	0B08348A	Power Cord (UK)	1	04	0M03985A	Control Motor Label	1
	0B08037U	Cord Bushing (U.S.A., Canada, Japan, 220V Class 2 & Others)	1	05	0M03988A	Motor Seal B	1
	0B08719A	Cord Bushing (Australia)	1	F01	CA08120A	Head Mount Base Assy	1
	0B08351A	Cord Bushing 4K-4 (UK)	1	01	0C08028C	Head Height Adjustment Gear	1
	0B08687A	Rear Panel	1	02	0C08027E	Head Height Adjustment Screw	2
02	0B06623A	6P DIN Socket	1	03	0C08026D	Azimuth Alignment Screw	1
	0B06622A	Power Transformer (U.S.A. & Canada)	1	04	0C08161B	Spring Stopper	1
	0B06624A	Power Transformer (220V Class 2, UK & Australia)	1	05	0C08131C	Head Plate Spring	1
	0B06625A	Power Transformer (Others)	1	06	CA08083C	Head Mount Base Sub Assy	1
	0C01162B	Belt Receptacle Plate	2	07	CA08144A	RP-9E Record/Playback Head Assy	1
	0J04076A	Power Switch Holder	1	F02	CA08053B	Supply Pressure Roller Assy	1
	0B07299A	Power Switch (U.S.A. & Canada)	1	01	0C08164G	Pressure Roller	1
	0B07301A	Power Switch (Japan)	1	02	0C08189B	Supply Tape Guide	1
	0B07252A	Power Switch (220V Class 2, Australia, UK & Others)	1	03	CA08061A	Supply Pressure Roller Arm Assy	1
	09	0J03663C	Power Switch (220V Class 2, Australia, UK & Others)	1	L01	0E00042A	E-Ring 1.5mm
0M03946A		Voltage Selector Lock Plate C	1	L02	0C08024A	Washer 2mm	2
0M03551B		Pass Label	1	L03	0E00788A	BT Screw M2x8 Phillips Pan Head	1
0M03794A		Voltage Label 100V (Japan)	1	F03	CA08079B	Take-up Pressure Roller Assy	1
0M03796A		Voltage Label 220V (220V Class 2)	1	01	0C08164G	Pressure Roller	1
0M03797A		Voltage Label 240V (UK & Australia)	1	02	0C08181C	Take-up Tape Guide	1
0M03956A		Voltage Label 120V/220-240V (Others)	1	03	CA08073B	Take-up Pressure Roller Arm Assy	1
0M04097B		Fuse Caution Label (U.S.A. & Canada)	1	L01	0E00042A	E-Ring 1.5mm	1
0B07092U		Voltage Selector (Others)	1	L02	0C08024A	Washer 2mm	2
0M03844B		Power Cord Label (UK)	1	L03	0E00788A	BT Screw M2x8 Phillips Pan Head	1
*12	0F01071A	Free-up Belt	1	F03	CA08079A	Take-up Pressure Roller Assy	1
	0M04055A	SDNF Label (220V Class 2)	1	Serial Nos.:	A304.501001 - A304.516073		
	0M03865A	Serial Number Plate	1	01	0C08164G	Pressure Roller	1
	0M04069B	Nakamichi Label (Japan)	1	02	0C08181B	Take-up Tape Guide	1
	0M03798A	Screw M2.6x6 Phillips Binding Head (Bronze)	2	03	CA08073B	Take-up Pressure Roller Arm Assy	1
	0E00071A	Screw M4x8 Phillips Binding Head (Bronze)	2	L01	0E00042A	E-Ring 1.5mm	1
	0E00756A	Screw M3x6 Phillips Binding Head (Black Chromate)	1	L02	0C08024A	Washer 2mm	2
	0E00860A	BT Screw M3x6 Phillips Binding Head (Black Chromate)	1	L03	0E00788A	BT Screw M2x8 Phillips Pan Head	1
	0E00502A	Screw M3x5 Phillips Pan Head	2				
	0E00563A	Screw M3x6 Phillips Binding Head (Bronze)	2				

9.13. Reel Motor Ass'y (E01)

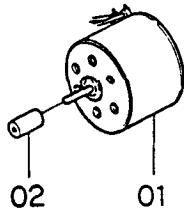

Fig. 9.13

9.14. Control Motor Ass'y (E02)

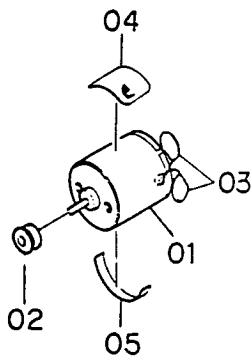

Fig. 9.14

9.15. Head Mount Base Ass'y (F01)

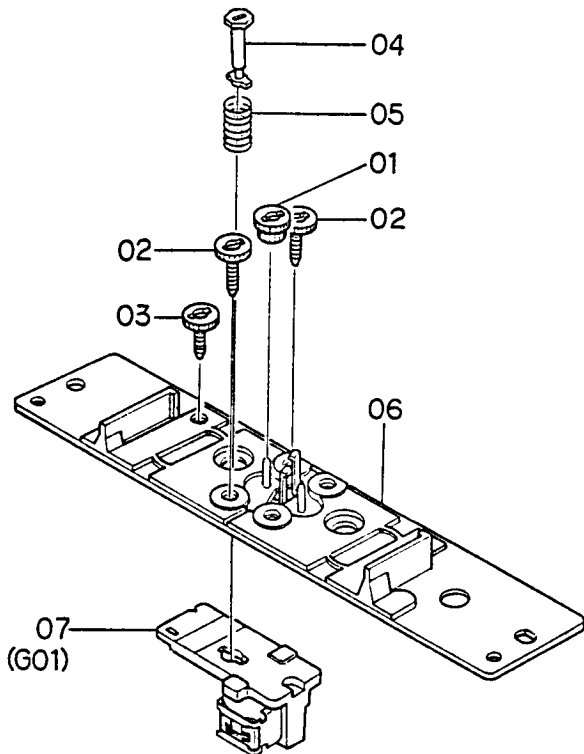

Fig. 9.15

9.16. Supply Pressure Roller Ass'y (F02)

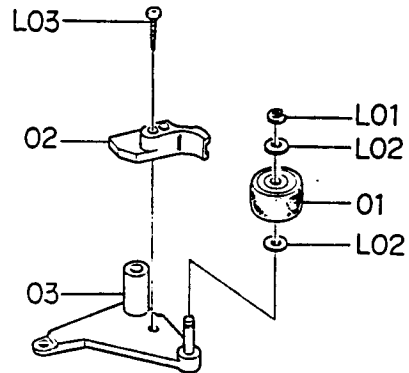

Fig. 9.16

9.17. Take-up Pressure Roller Ass'y (F03)

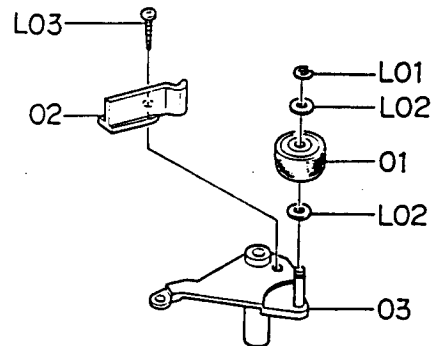

Fig. 9.17

For Service Manuals Contact
MAURITRON TECHNICAL SERVICES
8 Cherry Tree Rd, Chinnor
Oxon OX9 4QY
Tel:- 01844-351694 Fax:- 01844-352554
Email:- enquiries@mauritron.co.uk

9.18. Head Base Ass'y C (F04)

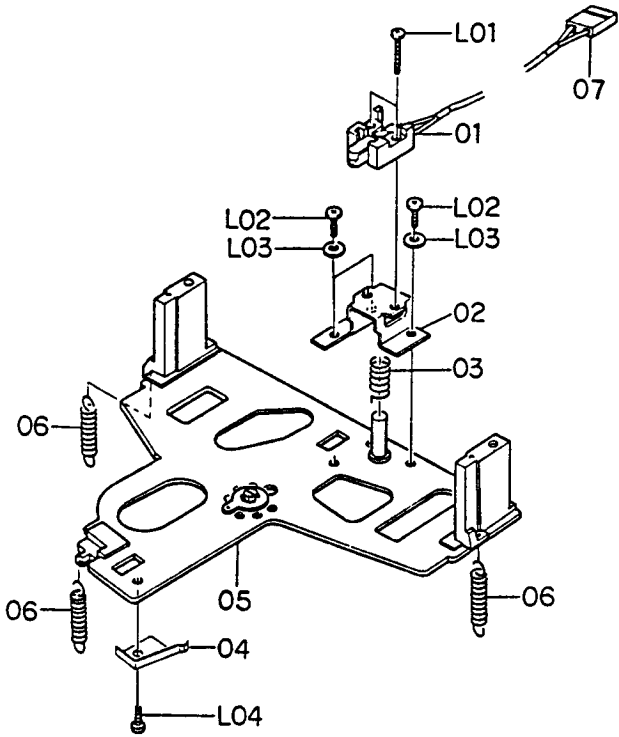

Fig. 9.18

9.19. Cassette Case Holder L Ass'y (F05)

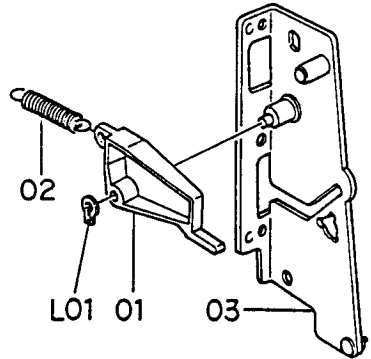

Fig. 9.19

9.20. Cassette Case Holder R Ass'y (F06)

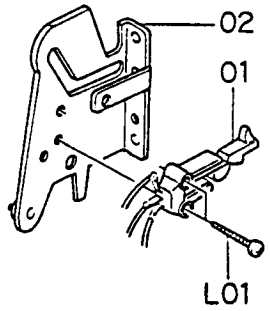

Fig. 9.20

9.21. Auto Shut-off Ass'y (F07)

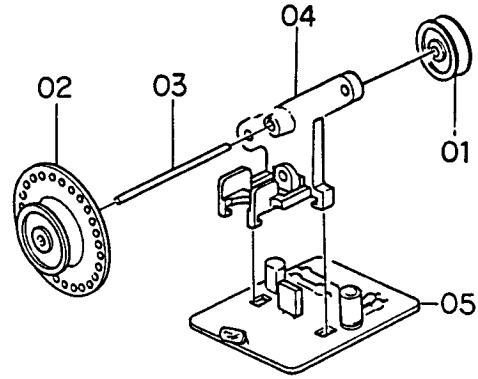

Fig. 9.21

9.22. Pneumatic Damper Ass'y (F08)

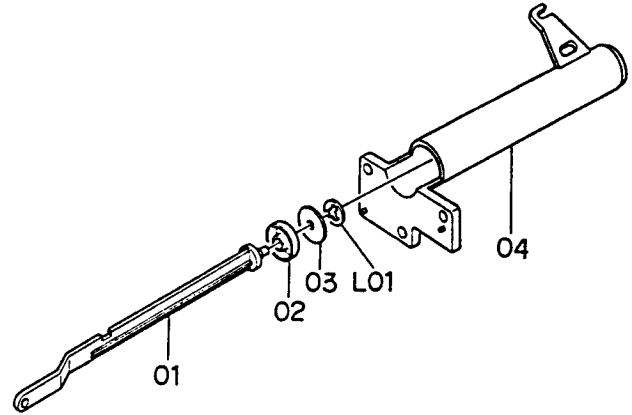

Fig. 9.22

9.23. RP-9E Record/Playback Head Ass'y (G01)

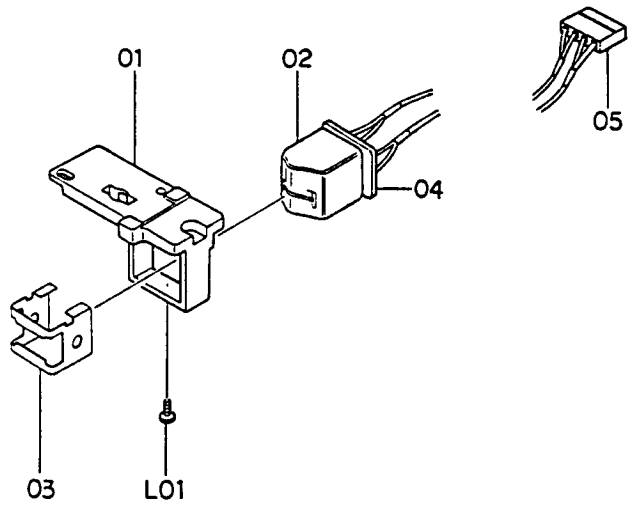

Fig. 9.23

Schematic Ref. No.	Part No.	Description	Q'ty
F04	CA08121A	Head Base Ass'y C	1
01	GA02017A	E-8L Erase Head	1
02	0C08158D	EH Hold Plate	1
03	0C08166A	EH Hold Plate Spring	1
04	0C08174C	Cassette Hold Spring	1
05	CA08003P	Head Base Ass'y	1
06	0C08175A	Head Base L Spring	3
07	0B08679D	2P-H Connector	1
L01	0E00889A	Screw M1.7x8 Philips Pan Head	2
L02	0E00909A	Screw M2x6 Philips Pan Head	3
L03	0E00117A	Washer 2mm	3
L04	0E00853A	BT Screw M2x3 Philips Pan Head	1
F05	CA08141A	Cassette Case Holder L Ass'y	1
01	0C08073C	Lid Arm A	1
02	0C08114A	Lid Arm Spring	1
03	CA08090F	Cassette Case Holder L Sub Ass'y	1
L01	0E00837A	Stopper Ring 3mm	1
F06	CA08022A	Cassette Case Holder R Ass'y	1
01	0C08133A	Eject Sensor	1
02	CA08044A	Cassette Case Holder R Sub Ass'y	1
L01	0E00840A	BT Screw M2x8 Philips Pan Head	2
F07	CA08119A	Auto Shut-off Ass'y	1
01	0C08047A	Shut-off Pulley A	1
02	0C08206B	Shut-off Pulley B	1
03	0C08088B	Shut-off Pulley Shaft	1
04	0C08207B	Shut-off Pulley Holder	1
05	BA04127A	Shut-off P.C.B. Ass'y	1
F08	CA08030A	Pneumatic Damper Ass'y	1
01	0C08058C	Damper Piston	1
02	0C08102B	Damper Ring	1
03	0C08010C	Damper Plate	1
04	0C08059D	Sylinder	1
L01	0E00874A	Stopper Ring CS 2mm	1
G01	CA08144A	RP-9E Record/Playback Head Ass'y	1
01	0C08217A	Head Plate	1
02	0G01294A	RP-9E Record/Playback Head	1
03	0C08216B	Pad Lifter 9E	1
04	0B07857A	Head Terminal P.C.B.	1
05	0B08678C	4P-H Connector	1
L01	0E00887A	Screw M1.7x4 Philips Pan Head	1

10. OVERALL TIMING CHART

Mode	PLAYBACK			RECORD				
Control Button	Stop	Play	Stop	Rec	Rec/Play	Rec/Pause	Rec/Play	Stop
Tape		470ms	120ms		840ms	130ms	220ms	130ms
		300ms	180ms		740ms	160ms	120ms	160ms
Output								
		300ms			560ms			
Bias								
					560ms			

Fig. 10

For Service Manuals Contact
MAURITRON TECHNICAL SERVICES
 8 Cherry Tree Rd, Chinnor
 Oxon OX9 4QY
 Tel: 01844-351694 Fax: 01844-352554
 Email: enquiries@mauritron.co.uk

11. EQ. AMP. FREQUENCY RESPONSE

11.1. Playback Frequency Response

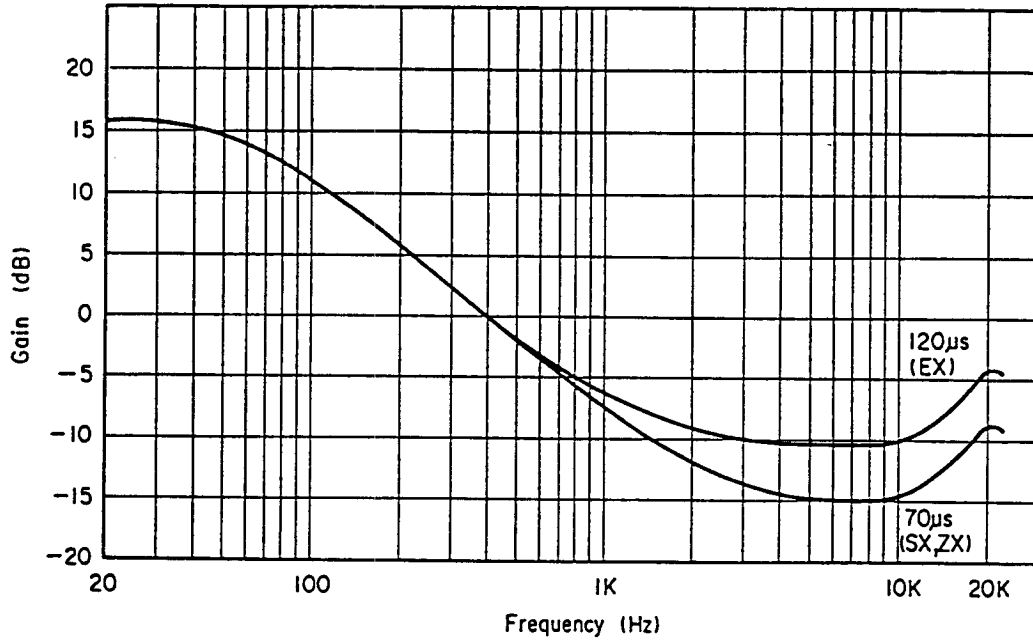

Fig. 11.1

11.2. Record Current Frequency Response

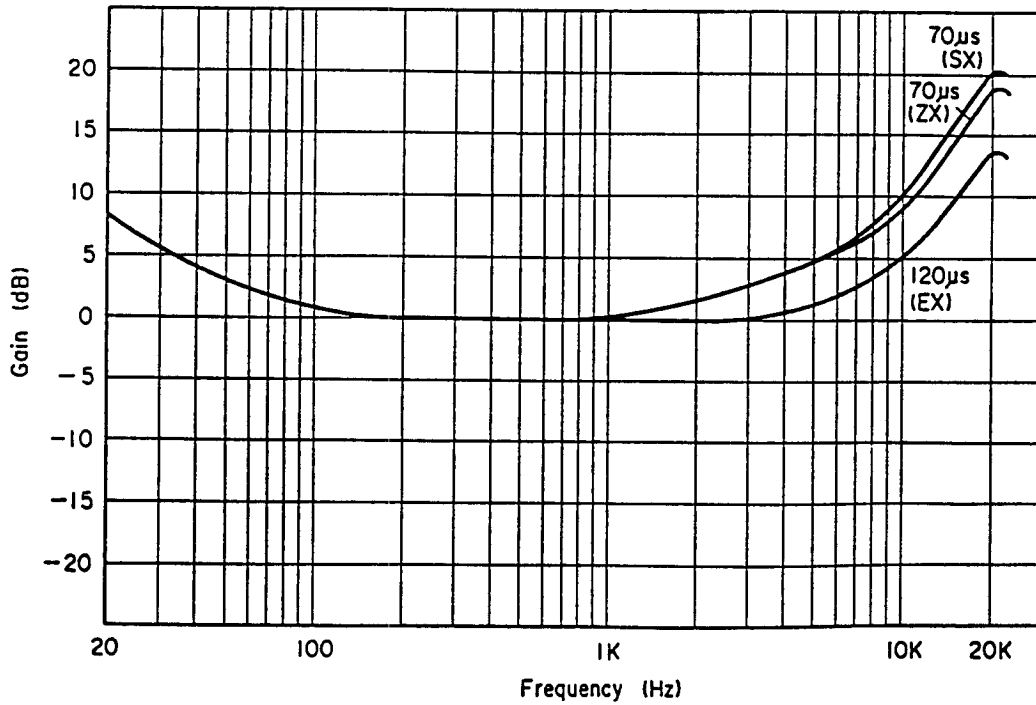
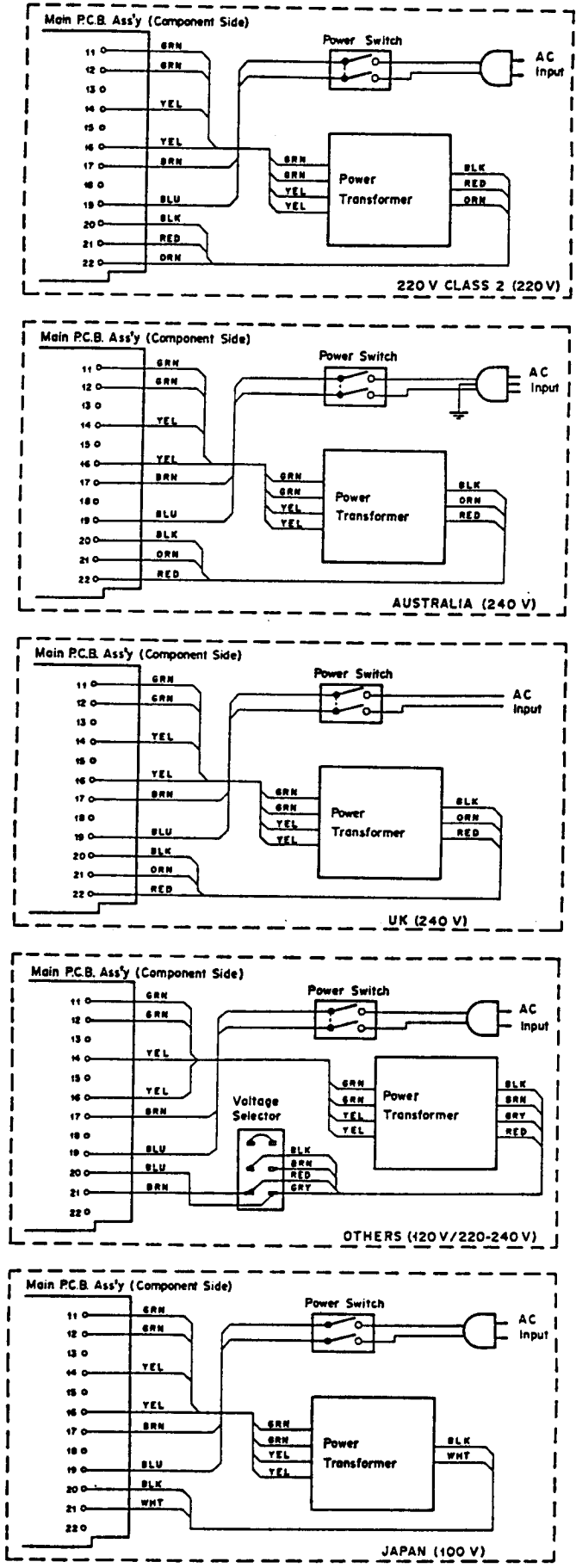

Fig. 11.2

For Service Manuals Contact
MAURITRON TECHNICAL SERVICES
8 Cherry Tree Rd, Chinnor
Oxon OX9 4QY
Tel:- 01844-351694 Fax:- 01844-352554
Email:- enquiries@mauritron.co.uk

12. WIRING DIAGRAM



Note: Table of colors
 BLK – Black
 BLU – Blue
 ORN – Orange
 GRY – Gray
 GRN – Green
 RED – Red
 BRN – Brown
 YEL – Yellow
 WHT – White
 VIO – Violet

Fig. 12.1

430

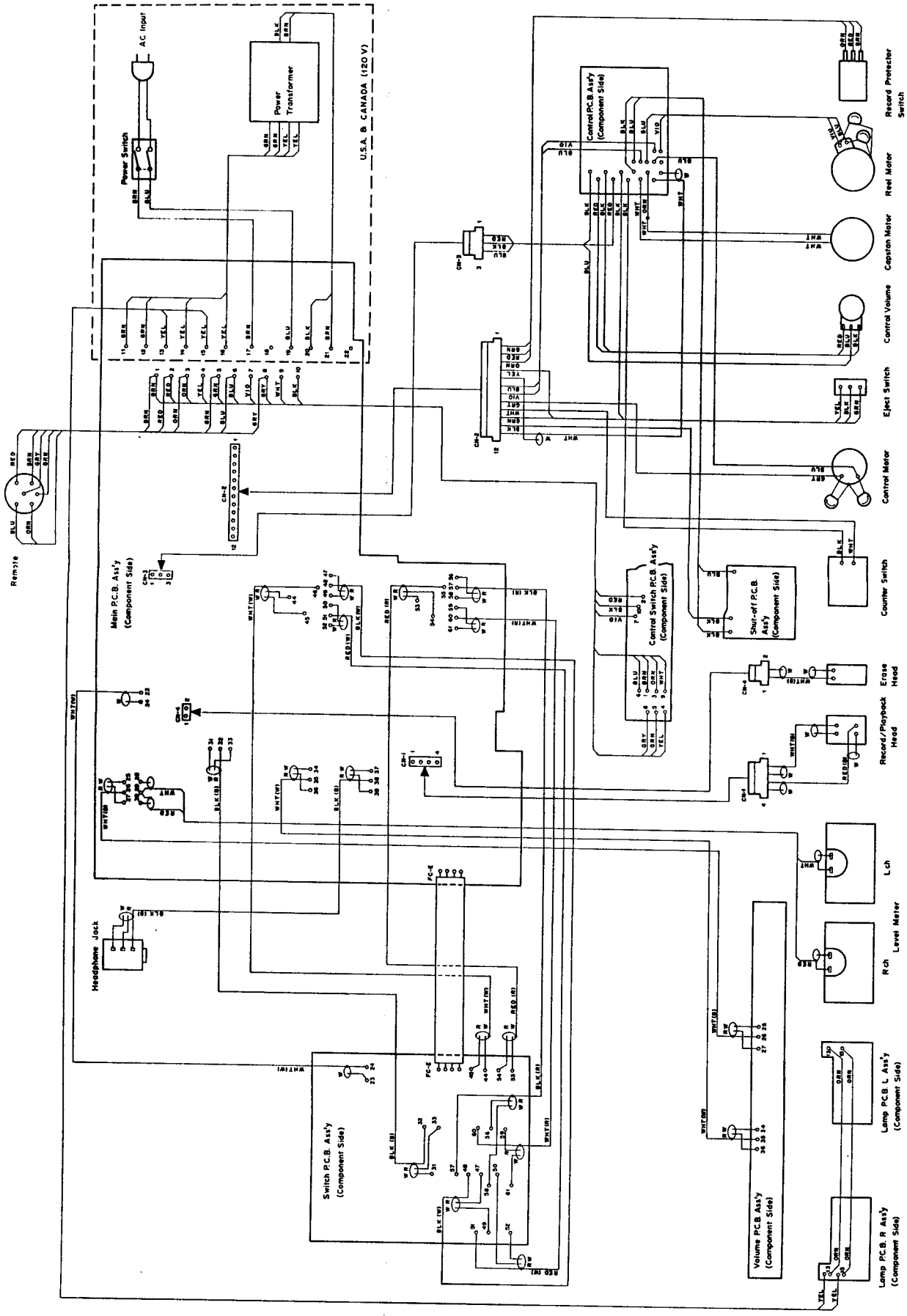

Fig. 1.2.2

13. BLOCK DIAGRAMS

13.1. Amplifier

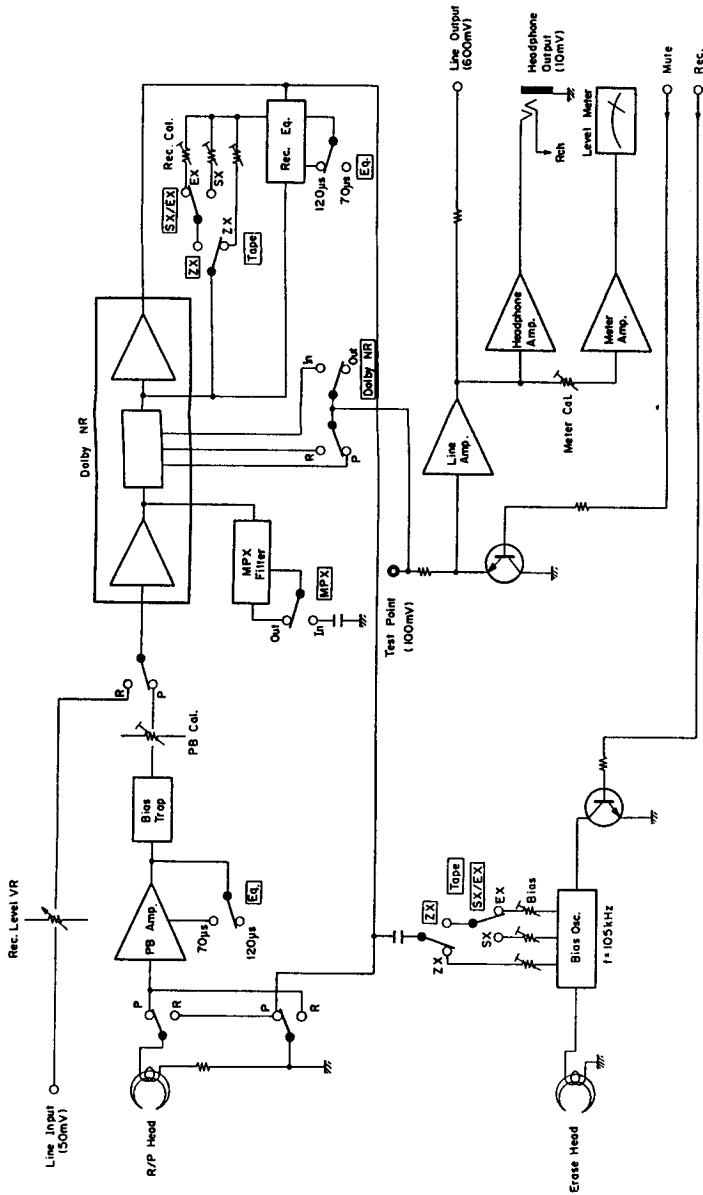

Fig. 13.1

For Service Manuals Contact
MAURITRON TECHNICAL SERVICES
 8 Cherry Tree Rd, Chinnor
 Oxon OX9 4QY
 Tel:- 01844-351694 Fax:- 01844-352554
 Email:- enquiries@mauritron.co.uk

13.2. Mechanism Control

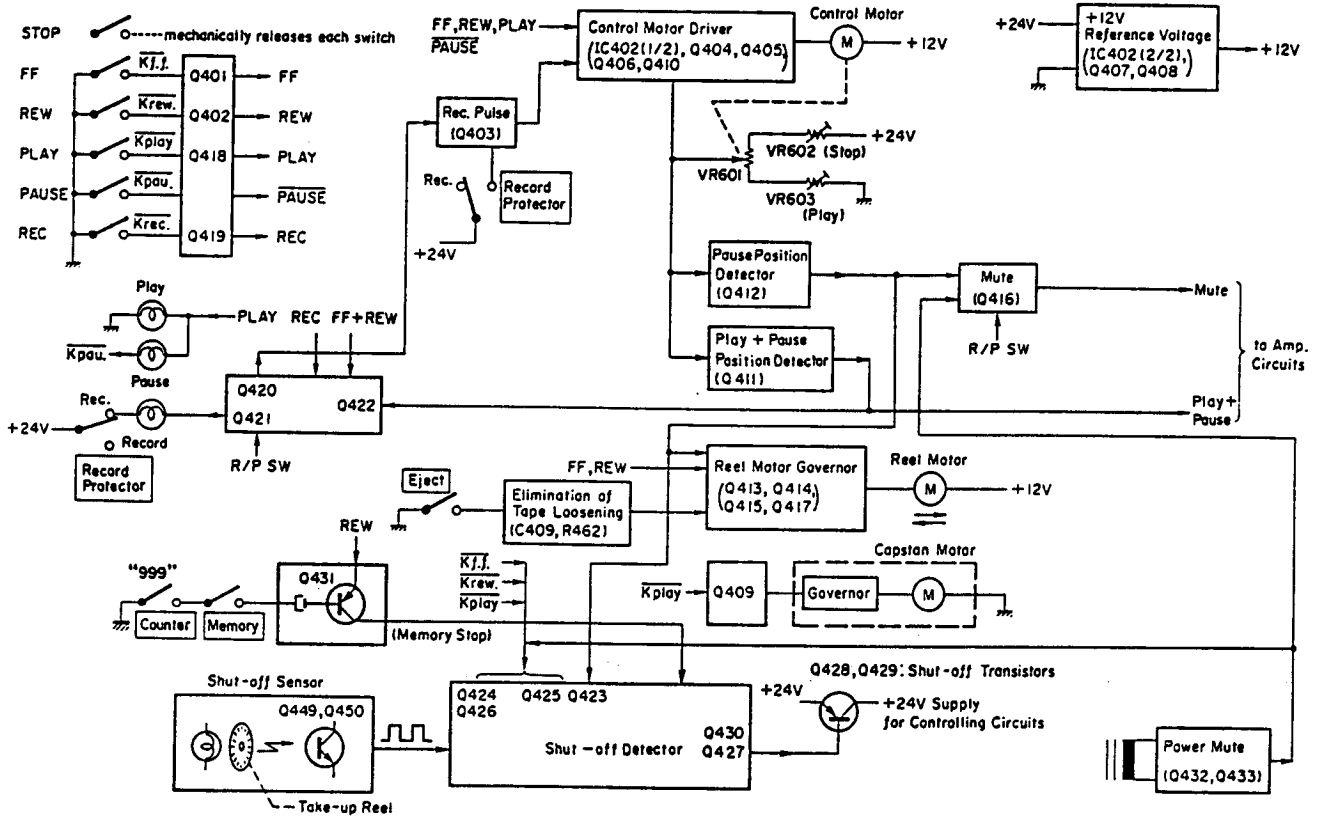

Fig. 13.2

14. SCHEMATIC DIAGRAMS

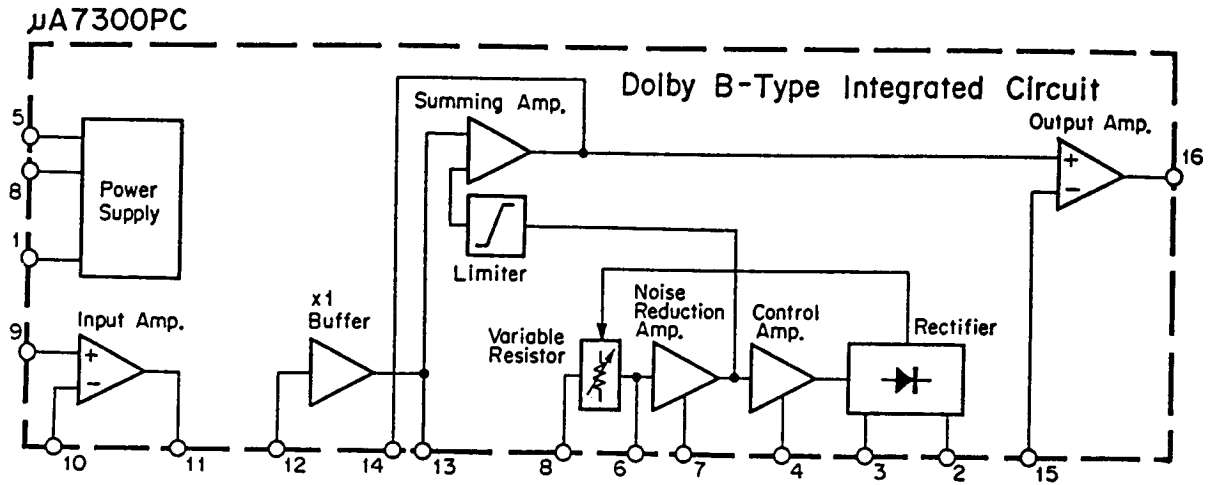

Fig. 14.1 Dolby NR IC μ A7300PC

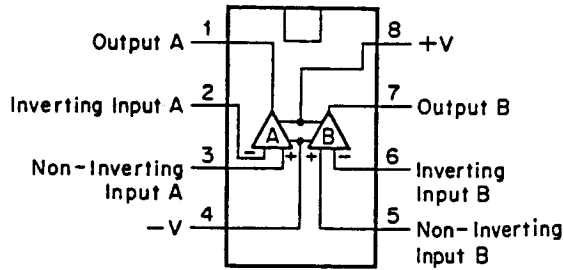
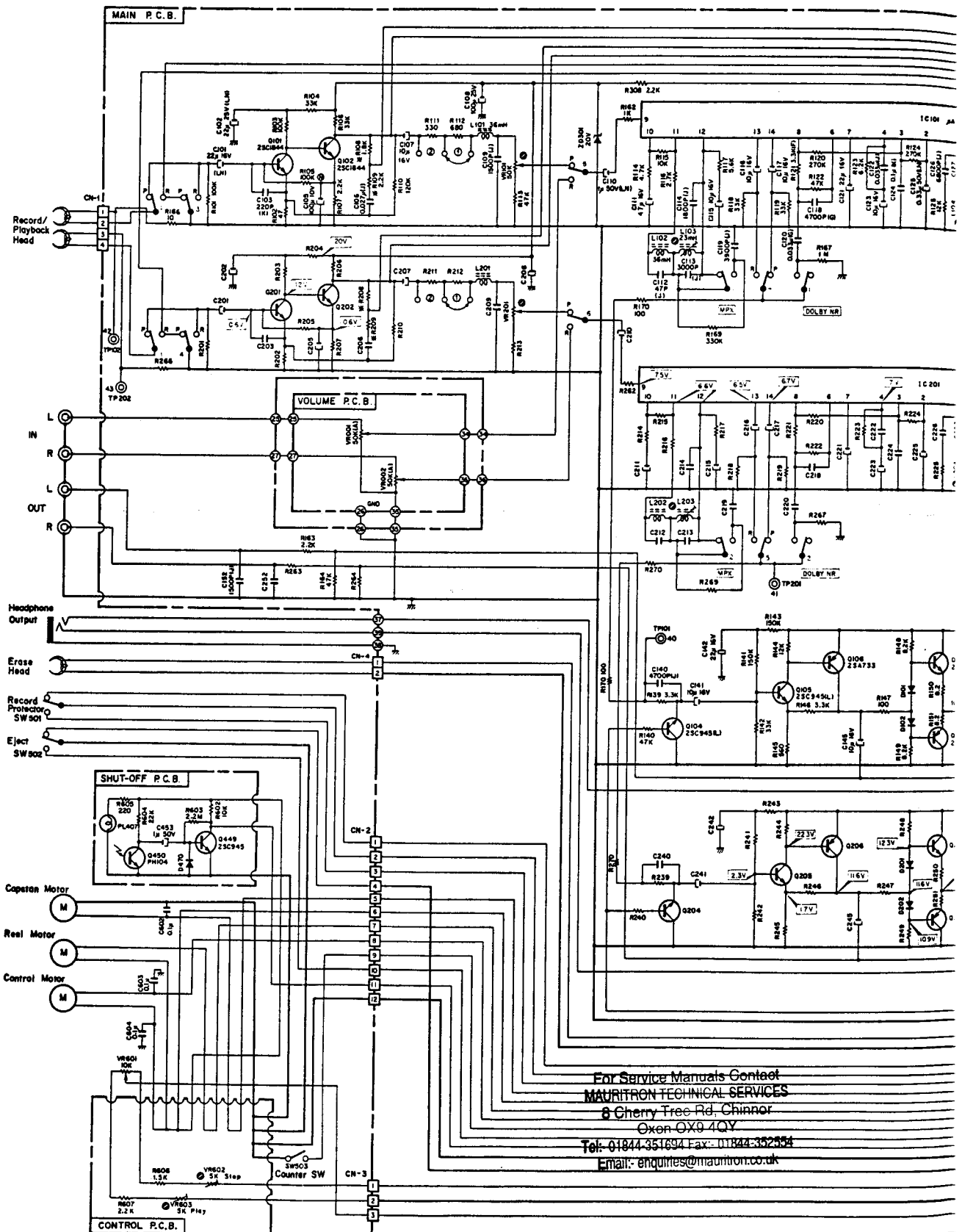

Fig. 14.2 Operational Amp. IC 4558

For Service Manuals Contact
MAURITRON TECHNICAL SERVICES
 8 Cherry Tree Rd, Chinnor
 Oxon OX9 4QY
 Tel:- 01844-351694 Fax:- 01844-352554
 Email:- enquiries@mauritron.co.uk



For Service Manuals Contact
MAURITRON TECHNICAL SERVICES
 8 Cherry Tree Rd, Chinnor
 Oxon OX9 4QY
 Tel: 01844-351694 Fax: 01844-352554
 Email: enquiries@mauritron.co.uk

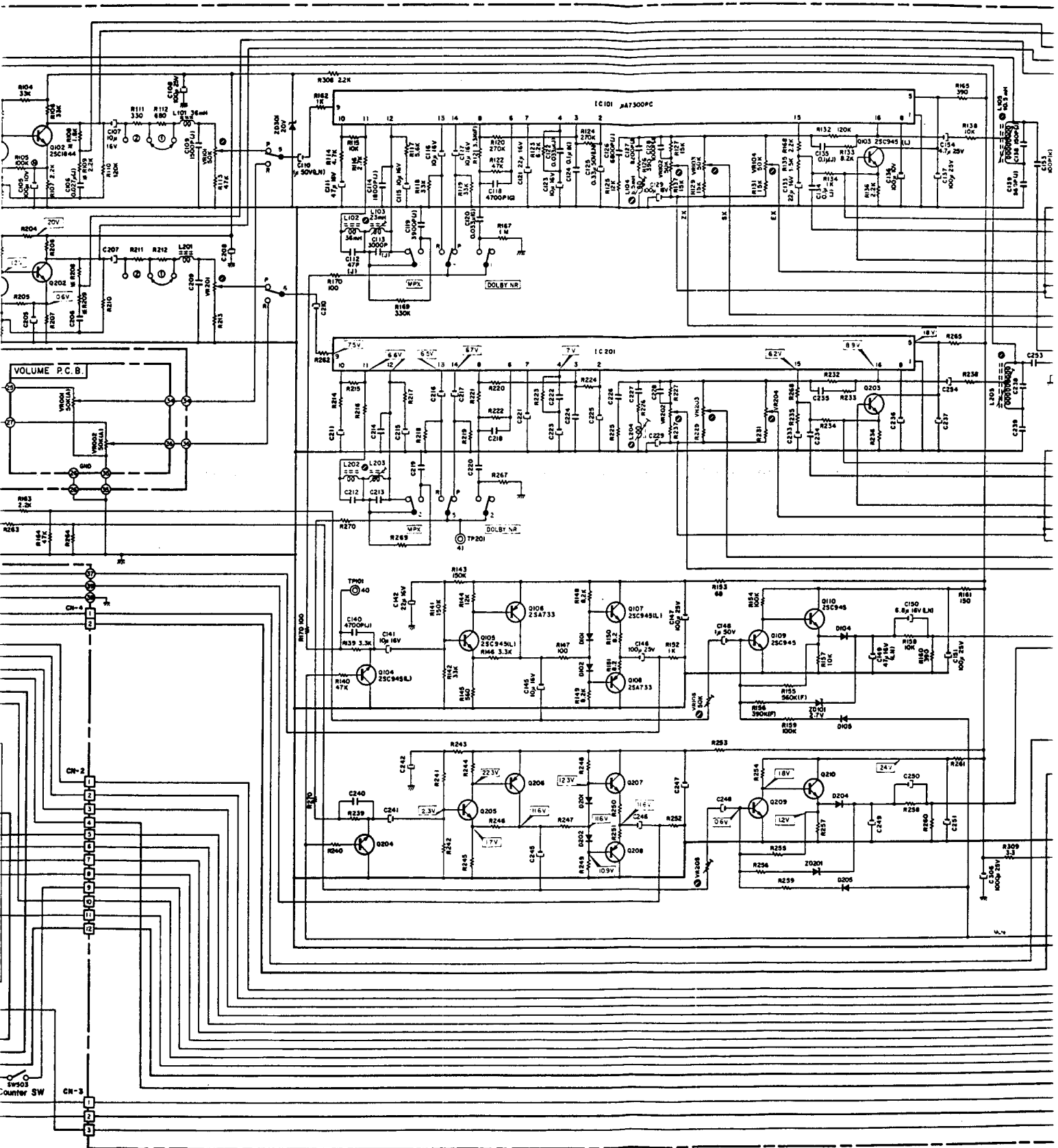
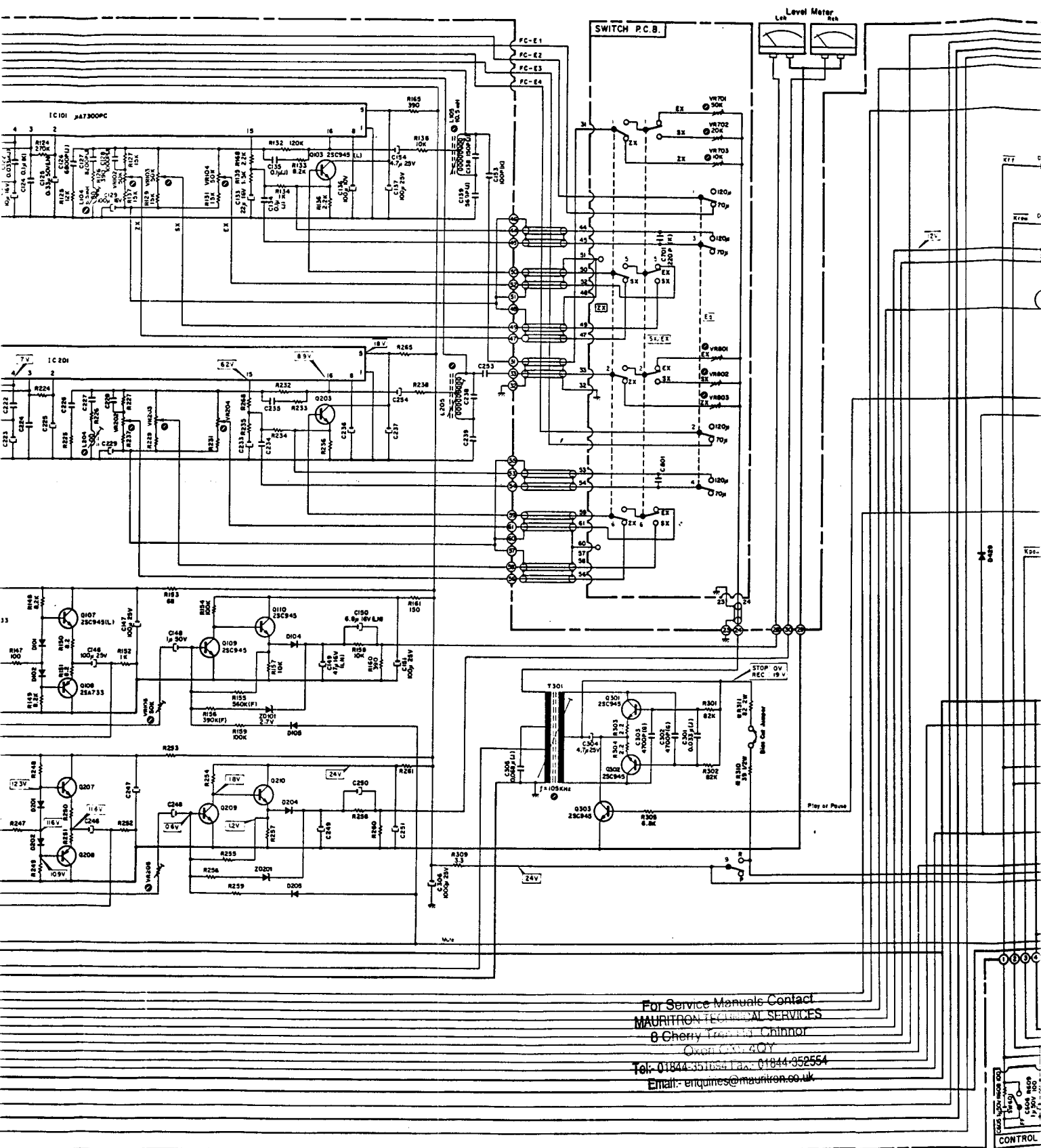

Fig. 14.3.1



For Service Manuals Contact
MAURITRON TECHNICAL SERVICES
 8 Cherry Trees, Chinnor
 Oxon OX3 2QY
 Tel: 01844-351154 Fax: 01844-352554
 Email: enquiries@mauritron.co.uk

Fig. 14.3.1 Serial No.: A304.518705 -

Notes: 1. Diode is 1SS53, 1S95
 2. Resistor and capcitio

Warning:

Parts marked with the symbol  have critical characteristics. Use ONLY replacement parts recommended by the manufacturer. It is recommended that the unit be operated from suitable DC supply or batteries during initial check-out procedure.

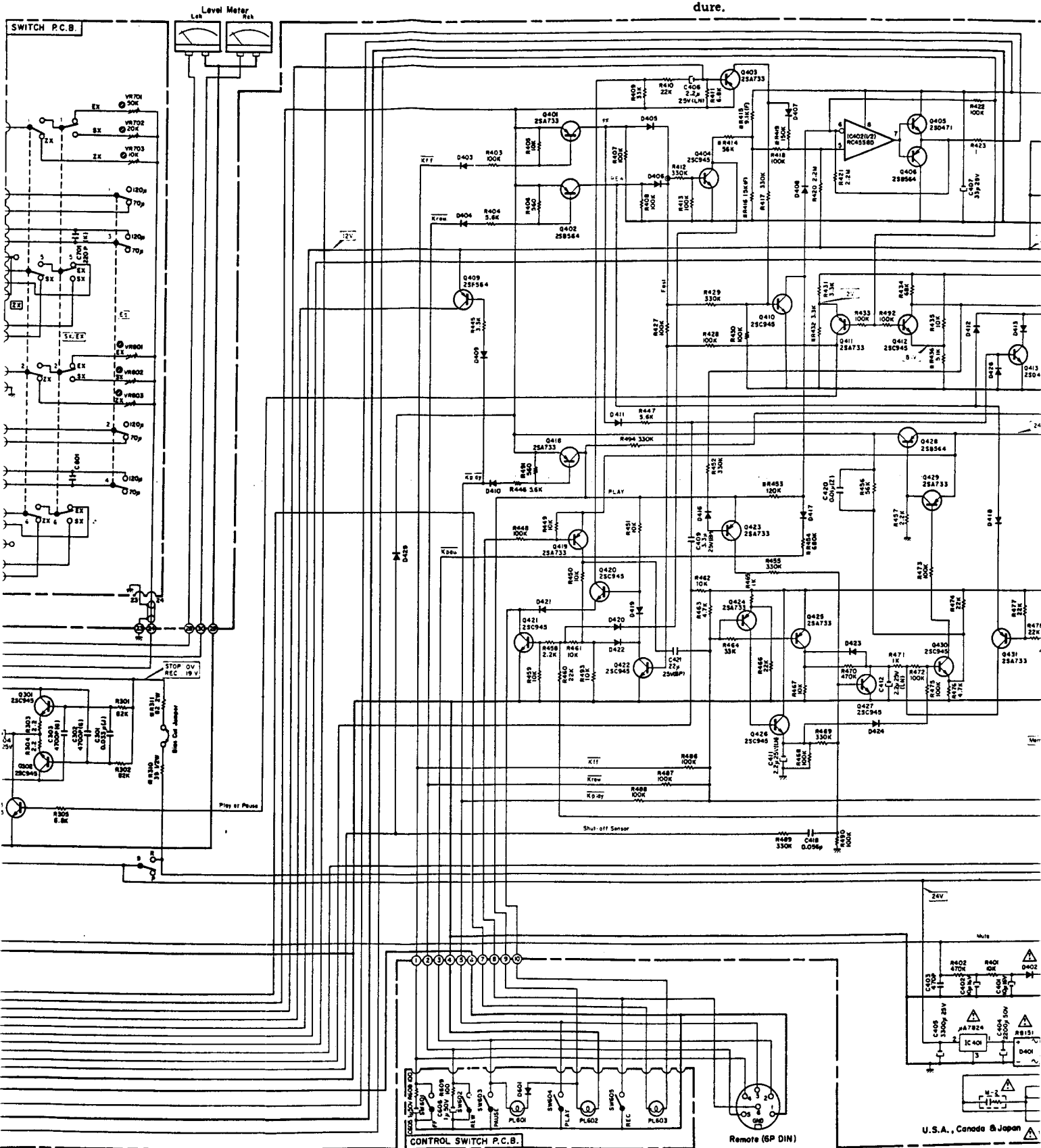

- Notes: 1. Diode is 1SS53, 1S953, or 1S1555 unless otherwise specified.
 2. Resistor and capacitor marked with * show typical value.

Warning: Components marked with the symbol  have critical characteristics. ONLY replacement parts recommended by the manufacturer. It is recommended that the unit be operated from a suitable DC supply or batteries during initial check-out procedure.

Caution:

Before returning the unit to the customer, make sure you make either (1) a leakage current check or (2) a line to chassis resistance check. If the leakage current exceeds 0.5 milliamp, or if the resistance from chassis to either side of the power cord is less than 240 k ohms, the unit is defective. **WARNING - DO NOT** return the unit to the customer until the problem is located and corrected.

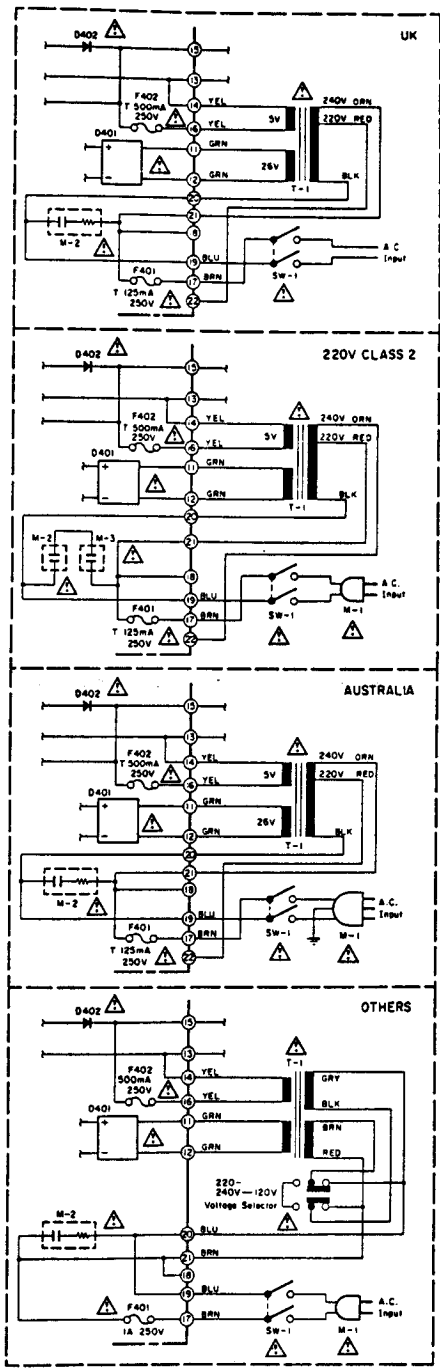
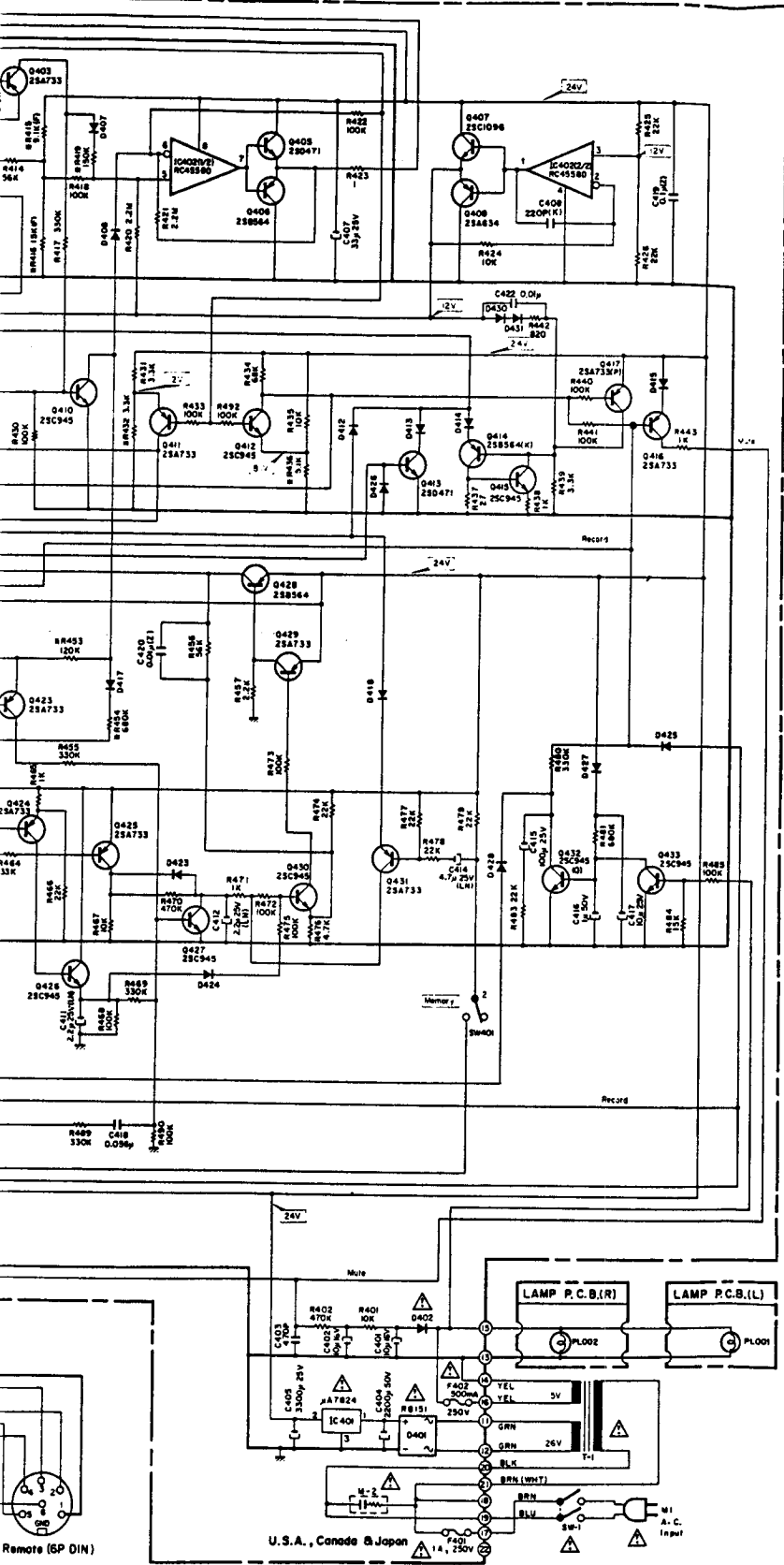

Switch Chart	
Description	Schematic Ref. Number
Record / Play	SW301
MPX	SW302
Dolby NR	SW303
ZX / EX	SW304
Eq.	SW306
Memory	SW401

For Service Manuals Contact
MAURITRON TECHNICAL SERVICES
 8 Cherry Tree Rd, Chinnor
 Oxon OX9 4QY
 Tel: 01844-351694 Fax: 01844-352554
 Email: enquiries@maurtron.co.uk

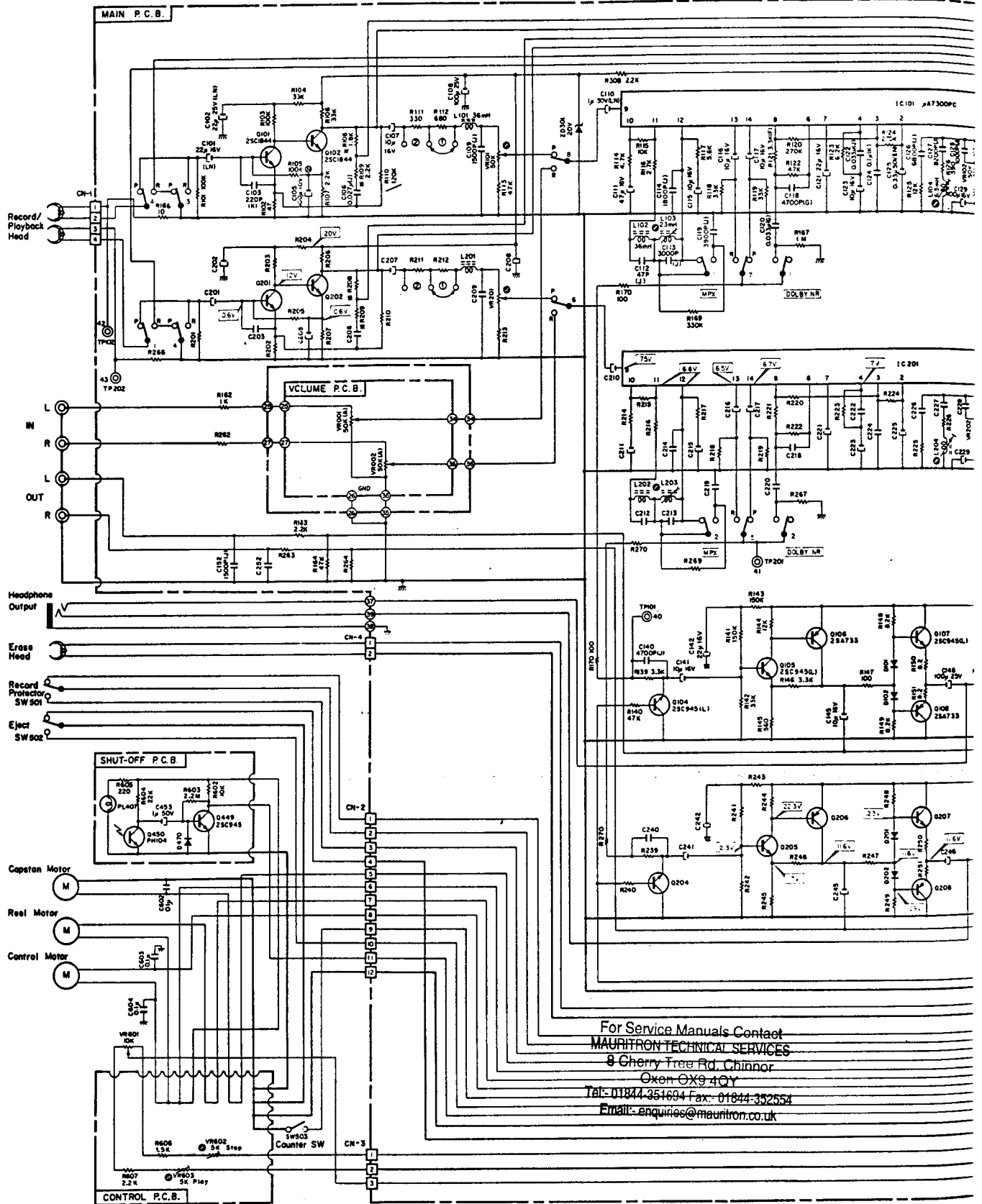

For Service Manuals Contact
MAURITRON TECHNICAL SERVICES
 8 Cherry Tree Rd, Chinnor
 Oxon OX9 4QY
 Tel: 01844 351694 Fax: 01844 352554
 Email: enquiries@mauritron.co.uk

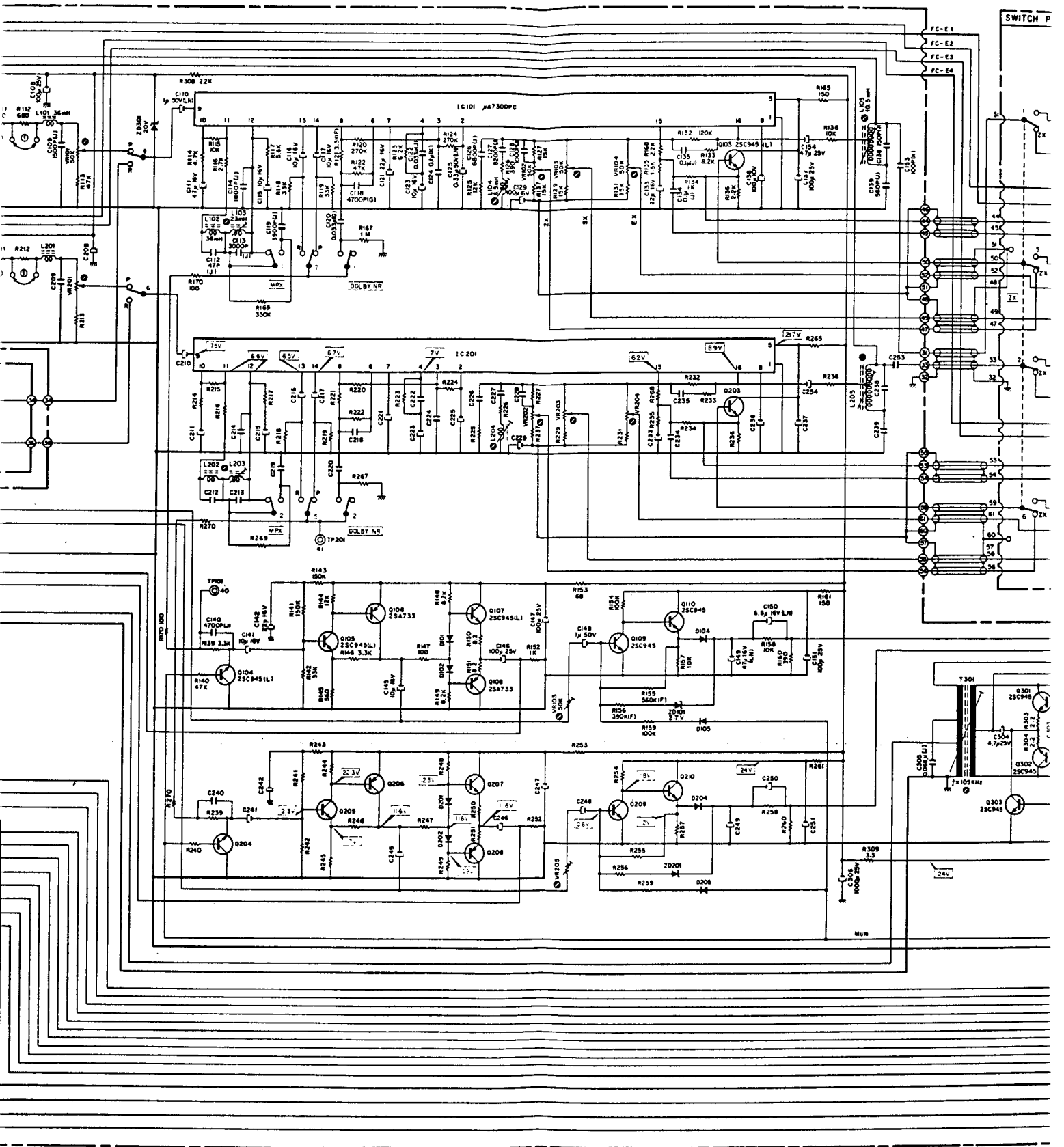
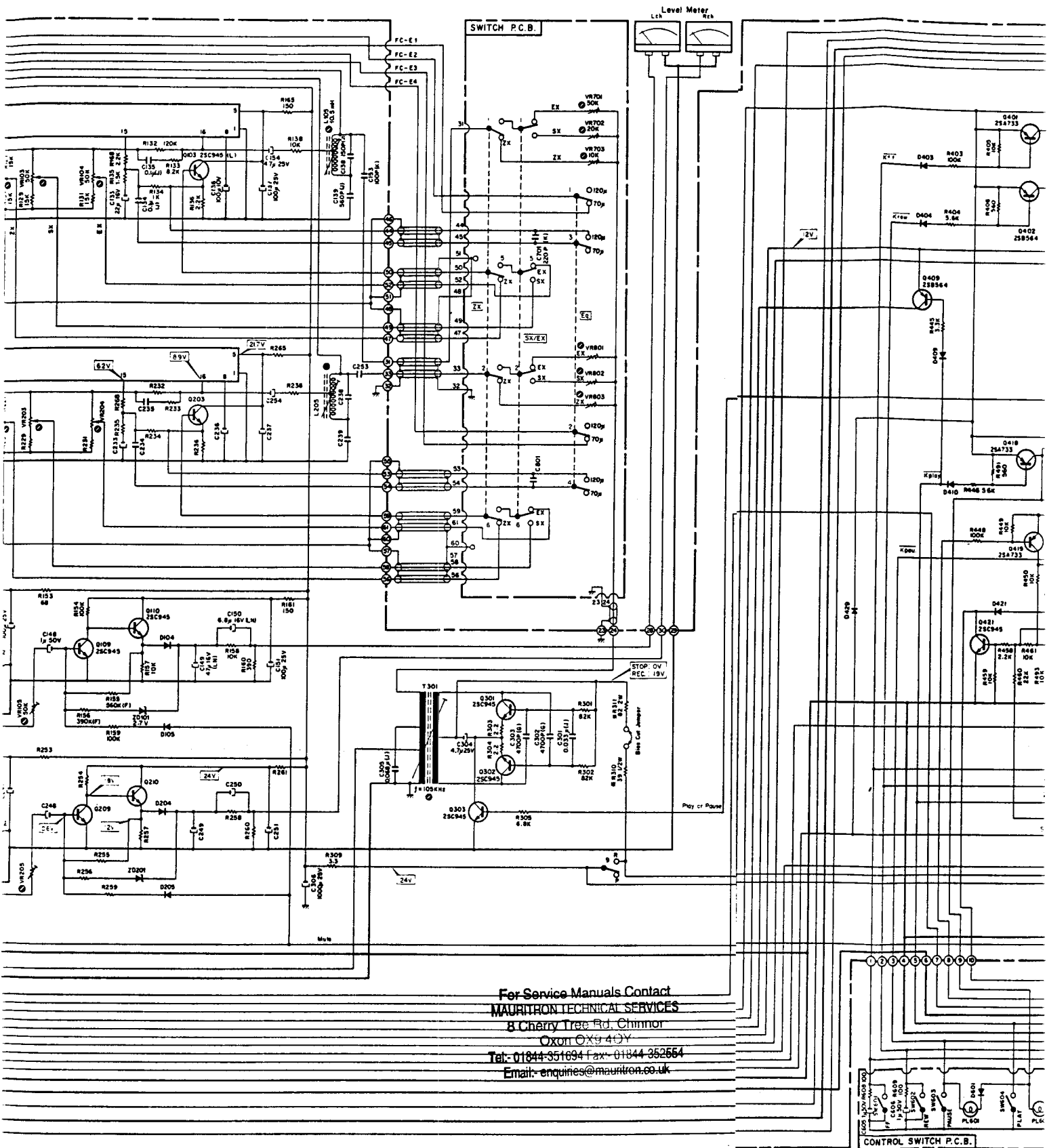



Fig. 14.3.2 Ser



For Service Manuals Contact
MAURITRON TECHNICAL SERVICES
 8 Cherry Tree Rd, Chinnor
 Oxon OX9 4DY
 Tel: 01844 351694 Fax: 01844 352664
 Email: enquiries@mauritron.co.uk

Fig. 14.3.2 Serial Nos.: A304.501001 – A304518704

Warning:
 Parts marked with the symbol  have critical characteristics.
 Use **ONLY** replacement parts recommended by the manufacturer. It is recommended that the unit be operated on a suitable DC supply or batteries during initial check-out.

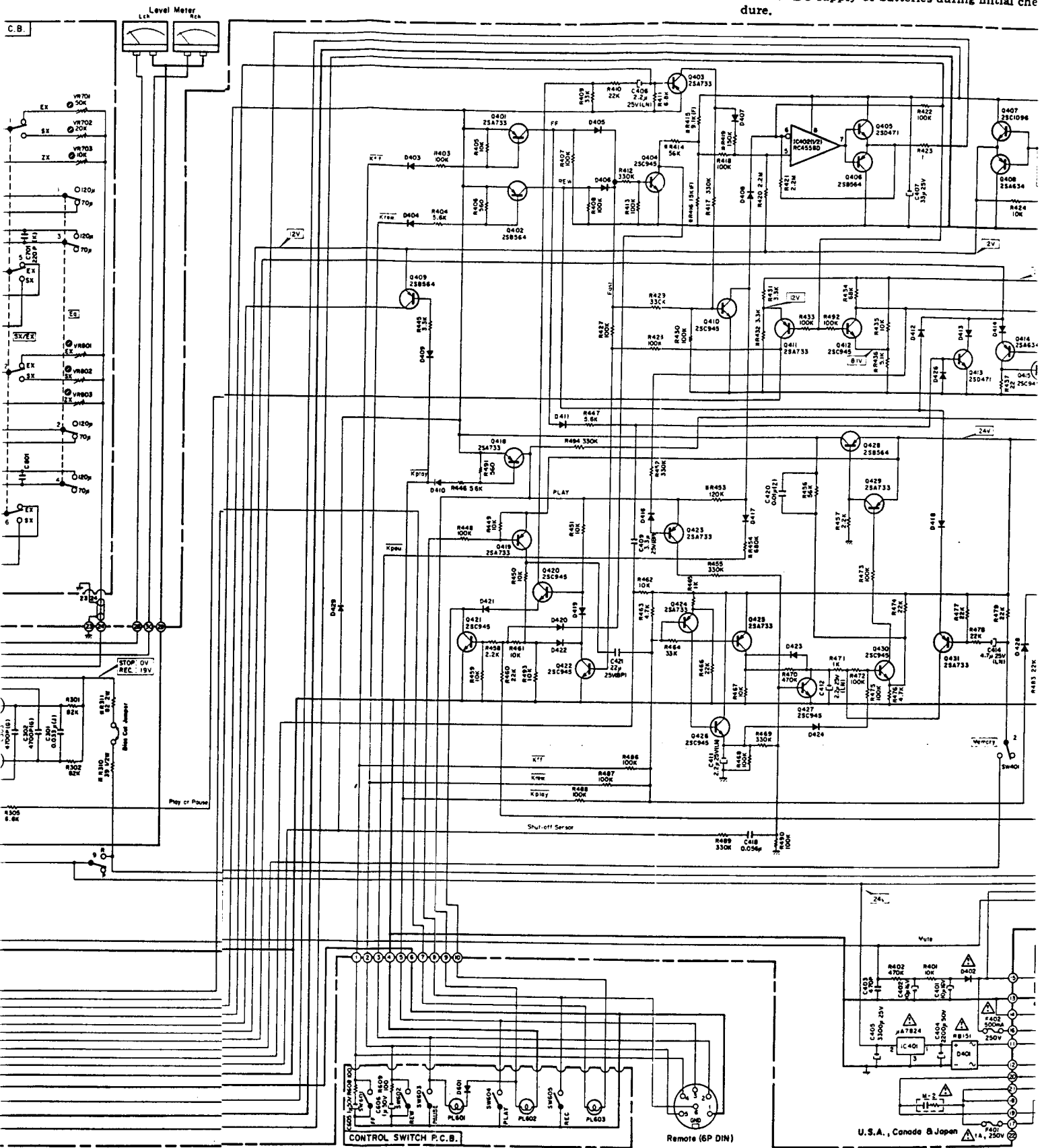

Serial Nos.: A304.501001 – A304518704

For Service Manuals Contact
MAURITRON TECHNICAL SERVICES
 8 Cherry Tree Rd, Chinnor
 Oxon OX9 4QY
 Tel: 01844-351694 Fax: 01844-352554
 Email: enquiries@mauritron.co.uk

- Notes: 1. Diode is 1SS53, 1S953, or 1S1555 unless otherwise specified.
- 2. Resistor and capacitor marked with * : indicate critical components.

Warning:
Parts marked with the symbol  have critical characteristics.

Use ONLY replacement parts recommended by the manufacturer. It is recommended that the unit be operated from a suitable DC supply or batteries during initial check-out procedure.

Caution:

Before returning the unit to the customer, make sure you make either (1) a leakage current check or (2) a line to chassis resistance check. If the leakage current exceeds 0.5 milliamp, or if the resistance from chassis to either side of the power cord is less than 240 k ohms, the unit is defective. **WARNING — DO NOT** return the unit to the customer until the problem is located and corrected.

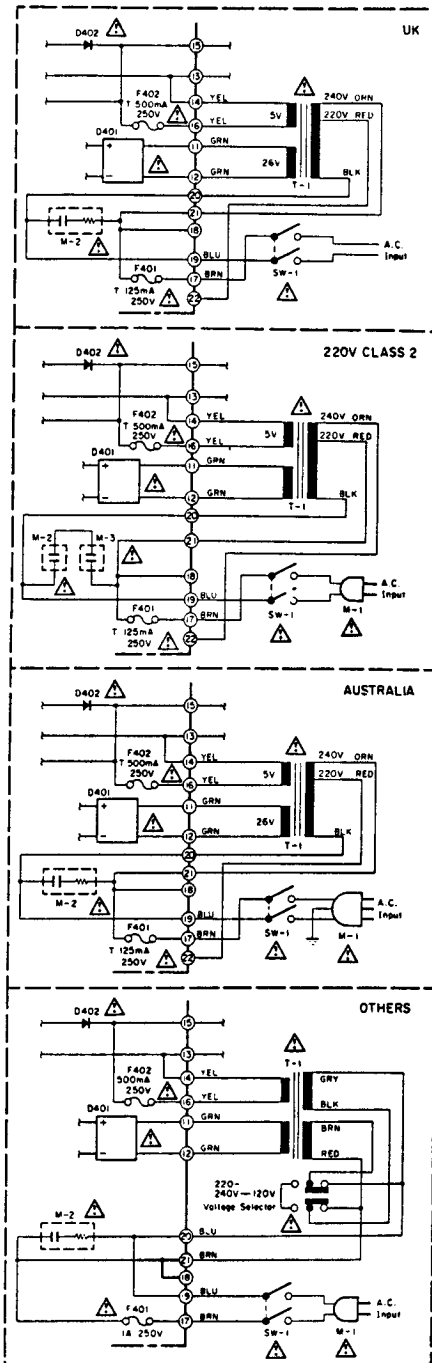
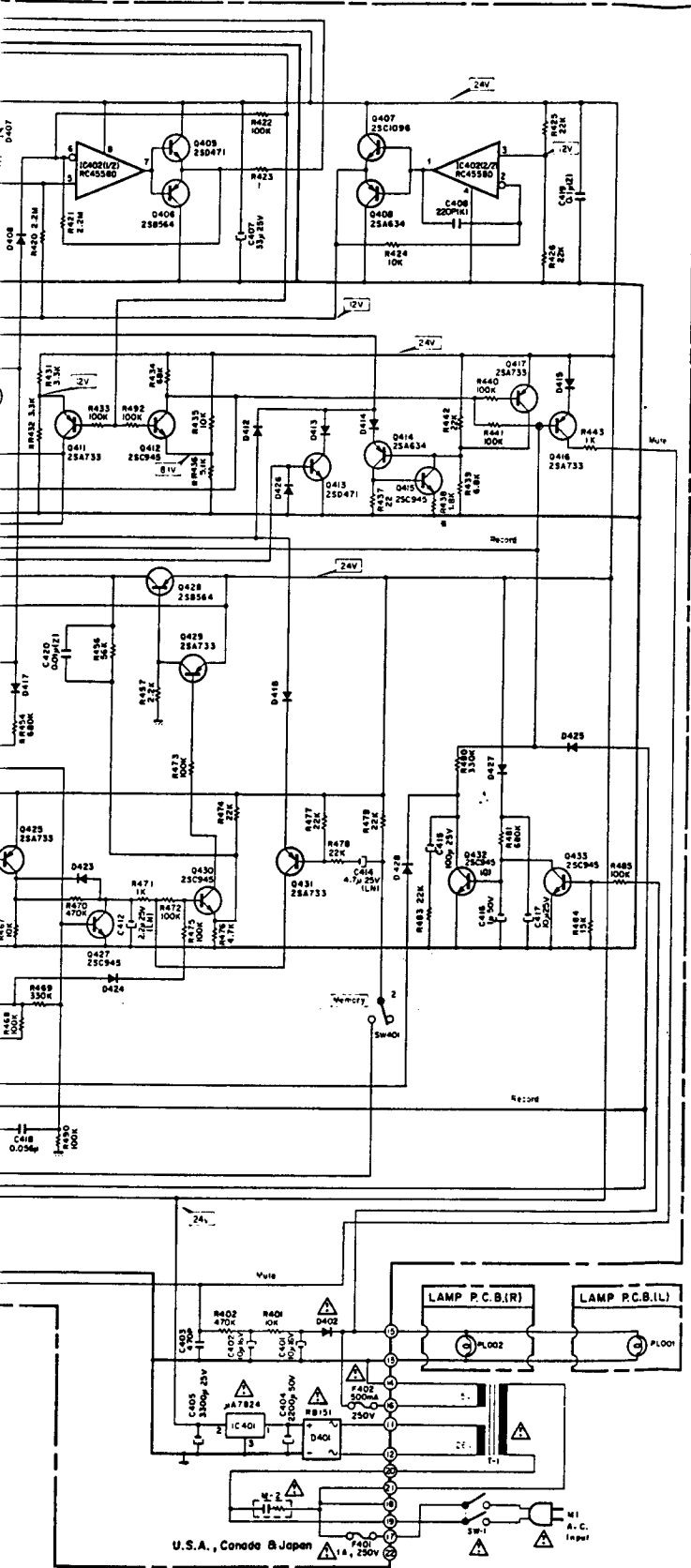

Switch Chart	
Description	Schematic Ref. Number
Record / Play	SW301
MPX	SW302
Dolby NR	SW303
ZX	SW304
SX/EX	SW305
Eq.	SW306
Memory	SW401

1. Diode is 1SS53, 1S953, or 1S1555 unless otherwise specified.
2. Resistor and capacitor marked with * show typical value.

For Service Manuals Contact
MAURITRON TECHNICAL SERVICES
8 Cherry Tree Rd, Chinnor
Oxon OX9 4QY
Tel: 01844-351694 Fax: 01844-352554
Email: enquiries@mauritron.co.uk

15. SPECIFICATIONS

Power Source	100, 120, 120/220-240, 220 or 240 V; 50/60 Hz (according to country of sale)
Power Consumption	23W Max.
Tape Speed	1-7/8 ips. (4.8 cm/sec.)
Wow-and-Flutter	Less than 0.12% WTD Peak, 0.06% WTD rms
Frequency Response	20-18,000 Hz \pm 4 dB (-20 dB Rec. Level)
Signal-to-Noise Ratio	Better than 62 dB at 400 Hz, 3% THD, WTD rms (Dolby NR In, 70 μ s)
Total Harmonic Distortion	Less than 1.0% at 400 Hz, 0 dB (ZX, EXII Tapes) Less than 1.2% at 400 Hz, 0 dB (SX Tape)
Erasure	Better than 60 dB below saturation level at 1 kHz
Separation	Better than 36 dB at 1 kHz, 0 dB
Crosstalk	Better than 60 dB at 1 kHz, 0 dB
Bias Frequency	105 kHz
Input	50 mV, 30 k ohms
Output Level	600 mV (400 Hz, 0 dB) 2.2 k ohms
Headphone	10 mW (400 Hz, 0 dB) 8 ohms
Dimensions	450(W) x 135(H) x 289(D) mm 17-23/32(W) x 5-5/16(H) x 11-3/8(D) inches
Approximate Weight	6.4 kg, 14 lb 2 oz.

- Specifications and appearance design are subject to change for further improvement without notice.
- Dolby NR under license from Dolby Laboratories.
- The word "Dolby" and the Double-D-Symbol are trademarks of Dolby Laboratories.

For Service Manuals Contact
MAURITRON TECHNICAL SERVICES
 8 Cherry Tree Rd, Chinnor
 Oxon OX9 4QY
 Tel:- 01844-351694 Fax:- 01844-352554
 Email:- enquiries@mauritron.co.uk